

FRITZ GABRIEL BAUER  
PRESENTS

THE USERS GUIDE TO THE  
SUPER - LIGHTWEIGHT MODULAR

*NOVICAN*  
**SL**

THE ADVANCED MOS MODULAR 35mm  
MOTION PICTURE CAMERA FOR MULTIPLE  
APPLICATIONS AND INCREASED UTILIZATION

**WEB-EDITION 2004**

Compiled by Frédéric Gérard Kaczek  
Illustrated by Andreas Pauleschitz

## TABLE OF CONTENTS

	<i>PREFACE</i>	5
	<i>MOVIECAM FEEDBACK MAIL</i>	6
	<i>SL CHECKLIST</i>	6
	<i>CARE AND CLEANING</i>	7
<b>1</b>	<b>BODY OF THE CAMERA SYSTEM</b>	
	<i>Camera front</i>	14
	<i>Camera left side</i>	16
	<i>Control board</i>	17
	<i>Display</i>	19
	<i>Camera rear</i>	21
	<i>Camera right side</i>	23
	<i>Camera top</i>	24
	<i>Viewfinder mount plate</i>	25
	<i>Camera base</i>	26
<b>2</b>	<b>OPTICAL VIEWFINDERS AND VIEWFINDER ADAPTER PLATE</b>	
	<i>SL viewfinder</i>	30
	<i>Mounting the SL viewfinder</i>	32
	<i>Eyecup</i>	33
	<i>Eyepiece retaining mount</i>	33
	<i>Eyepiece heater</i>	34
	<i>Adjustment of the pivoting eyepiece</i>	35
	<i>Diopter corrections</i>	36
	<i>SL B&amp;W video camera</i>	37
	<i>B&amp;W video assist monitor</i>	39
<b>3</b>	<b>SL VIDEO VIEWFINDERS, SL VIEWFINDER ADAPTER PLATE, READOUTS AND MOVIELITES</b>	
	<i>Viewfinder adapter plate</i>	42
<b>4</b>	<b>SL MAGAZINES</b>	
	<i>SL magazines</i>	48
	<i>Digital footage counter</i>	49
	<i>SL magazine interior</i>	51
	<i>Roller assembly</i>	52
	<i>Loading the SL magazines</i>	53

<b>5</b>	SL MAGAZINE ADAPTER AND OTHER MAGAZINES	
	<i>SL magazine adapter</i>	60
<b>6</b>	CARRYING HANDLE, LIGHTWEIGHT SL BASE AND HANDGRIPS	
	<i>SL carrying handle</i>	64
	<i>Right handgrip</i>	65
	<i>Left handgrip</i>	66
	<i>SL lightweight base plate</i>	67
<b>7</b>	INTERIOR OF THE SL	
	<i>Interior of the camera</i>	70
	<i>Pitch adjustment control</i>	71
	<i>Ground glasses</i>	72
	<i>Changing the ground glasses</i>	73
	<i>Upper aperture plate/gate</i>	75
	<i>Lower aperture plate</i>	78
	<i>Pressure plate</i>	80
	<i>Mirror shutter</i>	81
	<i>Setting the shutter angle</i>	82
<b>8</b>	POWER SUPPLIES	
	<i>Power supply unit</i>	86
	<i>Battery block</i>	88
	<i>Voltage stabilizer</i>	90
<b>9</b>	THREADING FILM IN THE SL	
	<i>Door lock</i>	94
	<i>Magazine/magazine adapter mounting rail</i>	95
	<i>Threading film in the SL</i>	96
	<i>Threading film using the SL magazine adapter</i>	98
	<i>Dust check knob</i>	107
<b>10</b>	ACCESSORY BOXES, REMOTE CONTROL AND IRIS CONTROL	
	<i>Accessory connector</i>	110
	<i>Accessory box interface</i>	111
	<i>Remote control</i>	112

<b>11</b>	<i>SUPPORT, FOLLOW FOCUS AND MATTE BOX</i>	
	<i>Base plate</i>	116
	<i>35/S35 base plate</i>	117
	<i>Lens support</i>	118
	<i>Studio follow focus</i>	120
	<i>Lightweight follow focus</i>	123
	<i>Matte box</i>	125

<b>12</b>	<i>MISCELLANEOUS AND APPENDIX</i>	
	<i>Assistant work light</i>	130
	<i>Tools</i>	131
	<i>Directors finder</i>	132
	<i>APPENDIX</i>	
	<i>CONNECTORS AND CABLES</i>	136

## PREFACE

*The MOVIECAM family has grown - we herewith proudly present our latest "offspring", the MOVIECAM SL. This very small camera has a weight of 12,55 lbs / 5,7 kg only incl. magazine for shoulder operation. Contrary to other "noisy" cameras, the SL makes, when shooting at 24 or 25 fps, just a pleasant, quiet buzzing sound (25 db). Together with the new body, two new SL MAGAZINES, an SL OPTICAL VIEWFINDER, an SL B&W VIDEO CAMERA and an SL CARRYING HANDLE system have been developed so far. In addition, two new SL ADAPTERS and an SL INTERFACE have been designed which allow to use several parts from other MOVIECAM cameras with the SL. For instance, all viewfinder systems of the MOVIECAM COMPACT, incl. several EYEPIECES, READOUTS, VIDEO CAMERAS, VIDEO ASSIST MONITORS and MOVIELITES as well as the MAGAZINES and ACCESSORY BOXES can be mounted on the SL. Please take the time to read the following pages carefully. You will see that this new camera offers you a great variety of possibilities and is at the same time easy to handle. For descriptions of all compatible parts of the MOVIECAM family, please consult the updated edition '95 of the COMPACT USERS GUIDE. For further general or technical information, please feel free to contact one of our MOVIECAM rental houses or directly the MOVIECAM Headquarters in Vienna, Austria (for addresses and phone numbers, see appendix). We built this camera for you – now you may enjoy the MOVIECAM SL!*

*Gabriel Bauer and Team, Vienna 1995*

## MOVIECAM FEEDBACK MAIL

*Like the MOVIECAM SL system itself, its users guide consists of several interchangeable parts that will continuously be updated. Just send an E-mail by pushing [HERE](#) directly to the Vienna Headquarters and future updates will be mailed to you free of charge. You may also use this mail to let us know any comments (e.g. proposals, or – if really necessary – complaints) you may have . . . . .*

## MOVIECAM SL CHECKLIST

*The attached checklist (see appendix), which is ready to be photocopied, gives a general overview of all modular parts of the MOVIECAM SL plus the compatible parts of the COMPACT system and might be of help when placing your order.*

### **Warning!**

**Socket and/or pinning might have been changed by some rental houses. Be aware of that when putting your equipment together.**

## CARE AND CLEANING

*Like the other MOVIECAM cameras, the MOVIECAM SL is almost maintenance-free. There is only one requirement for a smooth operation: **the camera has to be meticulously clean.** Therefore you should protect it against any dirt or smudges. Clean the camera exterior with window cleaner (caution - do not moisten connectors!). Cleaning the magazine exterior is identical whether it is of aluminum or carbon fiber.*

*Only when really necessary, e.g. to remove camera tape gum, should you use alcohol or benzine.*

**Caution: Never use acetone!**

*When applied properly, compressed air is the best cleaner; a vacuum cleaner or an air syringe will do fine.*

*Cotton tips, orangewood sticks, soft and hard brushes may be used for gentle cleaning.*

**Caution: The camera may be lubricated at a MOVIECAM service center only!**

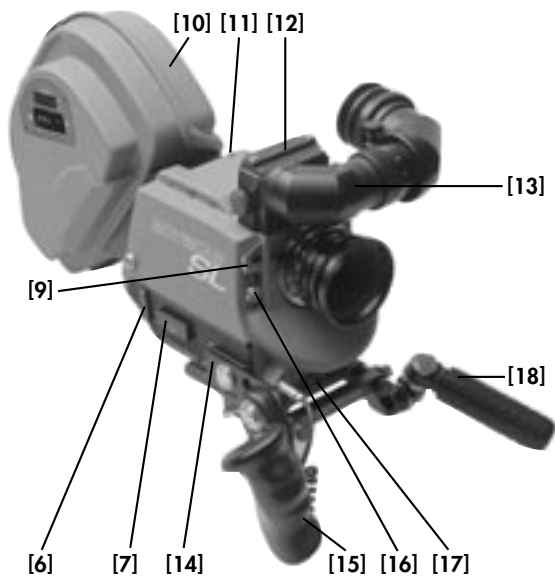
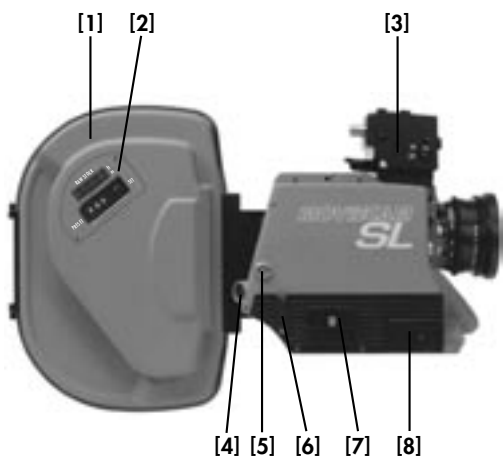

8

THE SL SYSTEM



- 1 400 FT/120 M STEADICAM SL MAGAZINE
- 2 FOOTAGE COUNTER WITH INPUT UNIT
- 3 SL VIDEO VIEWFINDER
- 4 POWER RECEPTACLE
- 5 SYNC OUT CONNECTOR
- 6 COVER PLATE OF MAIN FUSE HOLDER
- 7 ACCESSORY BOX INTERFACE PLUG
- 8 RIGHT HANDGRIP ATTACHMENT
- 9 ACCESSORY BRACKET
- 10 400 FT/120 M SL MAGAZINE
- 11 MAGAZINE/M. ADAPTER RELEASE BUTTON
- 12 COVER PLATE OF VIEWFINDER EXIT
- 13 SL VIEWFINDER
- 14 RIGHT HANDGRIP MOUNTING RAIL
- 15 RIGHT HANDGRIP
- 16 24V OUTLET
- 17 SL BASE PLATE
- 18 LEFT HANDGRIP
- 19 MULTI-FUNCTIONAL BUTTON
- 20 FPS INPUT UNIT/DISPLAY
- 21 ON/OFF BUTTON
- 22 DOOR LOCK
- 23 SL MAGAZINE LOCK
- 24 MATTE BOX
- 25 FILTER HOLDERS
- 26 ORIENTABLE VIEWFINDER ON ADAPTER PLATE
- 27 B&W VIDEO ASSIST
- 28 READOUT
- 29 MOVIELITE
- 30 B&W VIDEO CAMERA
- 31 LONG EYEPIECE
- 32 1000 FT/300 M MAGAZINE
- 33 LONG RODS
- 34 LENS SUPPORT BRACKET
- 35 FOLLOW FOCUS
- 36 BASE PLATE
- 37 SL MAGAZINE ADAPTER

- 1 400 FT/120 M STEADICAM SL MAGAZINE
- 2 FOOTAGE COUNTER WITH INPUT UNIT
- 3 SL VIDEO VIEWFINDER
- 4 POWER RECEPTACLE
- 5 SYNC OUT CONNECTOR
- 6 COVER PLATE OF MAIN FUSE HOLDER
- 7 ACCESSORY BOX INTERFACE PLUG
- 8 RIGHT HANDGRIP ATTACHMENT
- 9 ACCESSORY BRACKET
- 10 400 FT/120 M SL MAGAZINE
- 11 MAGAZINE/M. ADAPTER RELEASE BUTTON
- 12 COVER PLATE OF VIEWFINDER EXIT
- 13 SL VIEWFINDER
- 14 RIGHT HANDGRIP MOUNTING RAIL
- 15 RIGHT HANDGRIP
- 16 24V OUTLET
- 17 SL BASE PLATE
- 18 LEFT HANDGRIP
- 19 MULTI-FUNCTIONAL BUTTON
- 20 FPS INPUT UNIT/DISPLAY
- 21 ON/OFF BUTTON
- 22 DOOR LOCK
- 23 SL MAGAZINE LOCK
- 24 MATTE BOX
- 25 FILTER HOLDERS
- 26 ORIENTABLE VIEWFINDER ON ADAPTER PLATE
- 27 B&W VIDEO ASSIST
- 28 READOUT
- 29 MOVIELITE
- 30 B&W VIDEO CAMERA
- 31 LONG EYEPIECE
- 32 1000 FT/300 M MAGAZINE
- 33 LONG RODS
- 34 LENS SUPPORT BRACKET
- 35 FOLLOW FOCUS
- 36 BASE PLATE
- 37 SL MAGAZINE ADAPTER

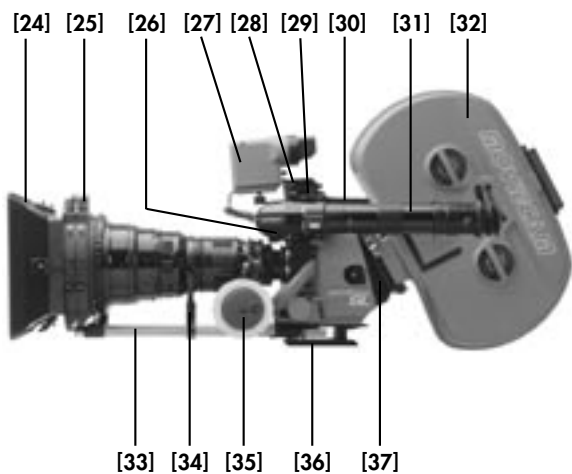
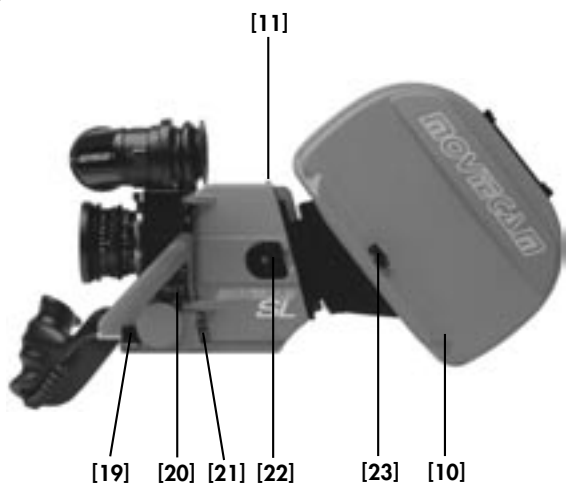

**Notes:**

# CHAPTER 1

THE BODY OF  
THE SL-SYSTEM

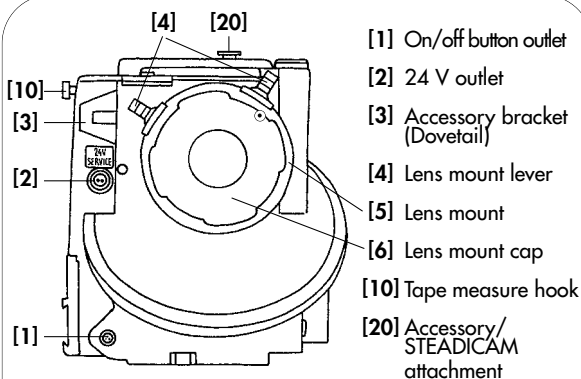

Fig. 2 – CAMERA FRONT

Contrary to the other MOVIECAM CAMERAS, the MOVIECAM SL is provided only with an ARRI PL lens mount [5]. Depending on the mounting, you can shoot either **STANDARD 35** or **SUPER 35** format. This choice has to be stated at the rental house where the necessary changes are made. To remove the MOUNT CAP [6] or the lens itself, turn the two bayonet levers [4] counter-clockwise. To mount a lens, turn the levers **gently** clockwise until the lens is seated properly. **Do not use force!**

Left of the lens mount there are two connectors. The top one [2] has a 24 V outlet, is protected by a 1,6 A multifuse and may be used for any remote-controlled device, e.g. zoom drive. In case of an external short circuit, e.g. defective zoom drive, the automatic multifuse cuts off the power supply of the connector. To reactivate the multifuse, remove the part that caused the short circuit; disconnect the camera for approx. 30 seconds, i.e. power supply has to be totally cut.

**Remark:** Depending on the customer's requests, the camera may be delivered with different types of connectors. Make sure that all the accessories, cables and plugs you order fit together. →

The lower connector **[1]** may be used for the remote control of the on/off button (e.g. *RIGHT HANDGRIP* button). The dovetail type accessory bracket **[3]** is used to hold the *CARRYING HANDLE* or the *LIGHTWEIGHT FOLLOW FOCUS* device.

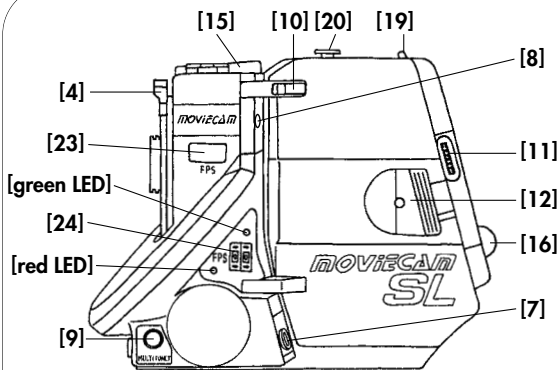

Fig. 3a - CAMERA LEFT SIDE

- [4] - Lens mount lever
- [7]- On/off button
- [8] - Connector 24 V / 400 mA
- [9] - Multi-functional button
- [10] - Tape measure hook
- [11] - Magazine / Magazine adapter connector
- [12] - Door lock
- [15] - Cover plate for Viewfinder exit
- [16] - Power receptacle
- [19] - Magazine / Magazine adapter release button
- [23] - FPS display
- [24] - FPS input unit
- [green LED] - Camera is running
- [red LED] - Battery low, out of sync

The door is located at the left side of the camera body. When it is closed, the door lock **[12]** must be flush with the door. By turning the door lock the door is firmly pressed onto the camera body so no light can enter.

In case of difficulties when closing the door, do not use force! Please check whether the movement is in its front position and the film guides are closed.





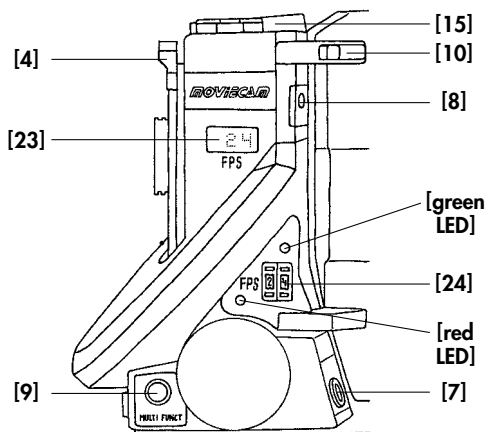

Fig. 3b – CONTROL BOARD

- [4] - Lens mount lever
- [7] - On/off button
- [8] - Connector 24 V / 400 mA
- [9] - Multi-functional button
- [10] - Tape measure hook
- [15] - Cover plate for Viewfinder exit
- [23] - FPS display
- [24] - FPS input unit
- [green LED] - Camera is running
- [red LED] - Battery low, out of sync

Power (24 V) for eyecup heater or ASSISTANT WORK LIGHT is supplied via the connector [8].

The tape measure is attached to the hook [10] that indicates the image plane.

The multi-functional button [9] has the following three functions: →

## **CAMERA IS OFF:**

### **1. Take-up function:**

*By shortly pressing this button, the film is tightened by the two magazine winders.*

### **2. Dust-check function:**

*By pressing this button **approx. 2 seconds**, the mirror shutter is cleared out of the way and thus permits to check the film gate without having to open the camera door.*

## **CAMERA IS ON:**

### **3. TV-bar function:**

*By pressing this button during shooting, the image separation bar on the TV or computer screen may be shifted toward the bottom of the viewfinder image. As long as the bar remains in this position, it is not visible on film.*

*The camera is switched on by activating either the button **[7]**, the *RIGHT HANDGRIP* button or the button on the *REMOTE CONTROL*.*

*Equally, any of those buttons can be employed to switch off the camera, and vice versa.*

Fig. 3c – DISPLAY

Following information is provided by the display on the control board of the MOVIECAM SL, on the READOUT or on the REMOTE CONTROL BOX

– MOVIECAM SL without ACCESSORY BOX:

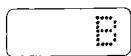

Flashing when a buckle switch has been interrupted (e.g. badly threaded film).



Stand-by camera.

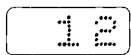

Lighting when camera runs with 12 fps. Flashing when lower speed has been selected.

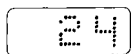

Lighting when camera runs with 24 fps.



Lighting when camera runs with 32 fps. Flashing when a higher speed has been selected.



Flashing when multi-functional knob is pressed and mirror shutter is in shooting position.

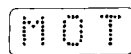

Shows malfunction of the driving system (motor, electronics).

– MOVIECAM SL with ACCESSORY BOX:

MSP

Flashing when speed either too high or low has been selected on SUPER SPEED CONTROL BOX.

2

Lighting when camera runs with 2 fps.  
Flashing when lower speed has been selected.

40

Lighting when camera runs with 40 fps.  
Flashing when higher speed has been selected.

- 12

Reverse shooting with 12 fps.  
Flashing when lower reverse speed has been selected.

- 24

Reverse shooting with 24 fps.

- 32

Reverse shooting with 32 fps.  
Flashing when higher reverse speed has been selected.

SFR

Shown when mirror shutter, controlled via single frame connector, remains in shooting position (approx. 4 seconds).

FWD

Shown when reverse mode is chosen (SUPER SPEED CONTROL BOX) and an SL MAGAZINE is mounted.

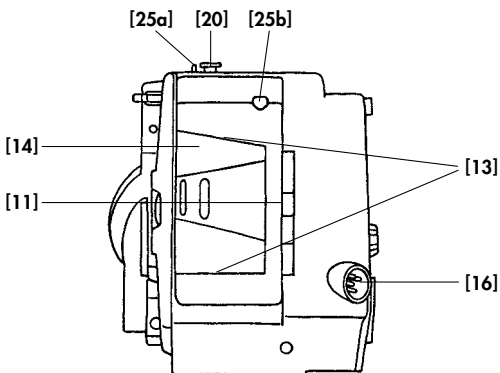

Fig. 4a – CAMERA REAR

- [11] - Magazine / Magazine adapter connector
- [14] - Camera opening
- [16] - Power receptacle
- [13] - Magazine / Magazine adapter mounting rails
- [20] - Accessory / STEADICAM attachment
- [25a] - Magazine / Magazine adapter release button
- [25b] - Magazine / Magazine adapter lock

The connector **[11]**, mounted mobile to facilitate the plug-in, is used for both electronic interface and power supply for the magazine drives.

The MAGAZINES (or MAGAZINE ADAPTER) are attached at the camera rear by sliding them onto the mounting rail **[13]**.

Below the magazine lower mounting rail there is the receptacle **[16]** for the camera's 24 V power supply.

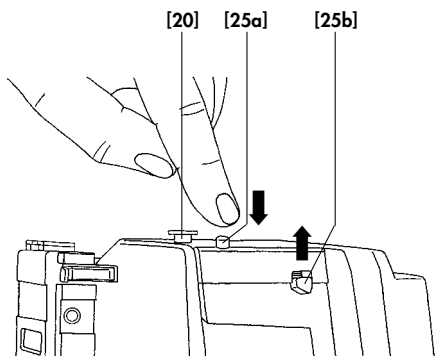

Fig. 4b – MAGAZINE/M.ADAPTER LOCK

On top of the camera rear, there is a small unlocking button **[25a]**. When mounting the SL MAGAZINE or the SL MAGAZINE ADAPTER to the camera, you will hear a click which indicates that the lock **[25b]** itself is engaged in the MAGAZINE/MAGAZINE ADAPTER notch and the MAGAZINE/MAGAZINE ADAPTER is firmly mounted. By pressing the small unlocking button **[25a]**, the lock shifts upwards and the MAGAZINE/MAGAZINE ADAPTER can be removed by pulling it gently outward.

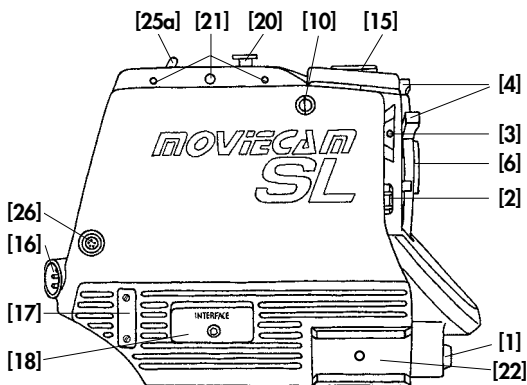

Fig. 5 – CAMERA RIGHT SIDE

- [1] - On/off button outlet
- [2] - 24 V outlet
- [3] - Accessory bracket (Dovetail)
- [4] - Lens mount lever
- [6] - Lens mount cap
- [10] - Tape measure hook
- [15] - Cover plate for VIEWFINDER exit
- [16] - Power receptacle
- [17] - Cover plate of the main fuse holder
- [18] - Accessory bracket
- [18] - Cover plate for accessory box interface plug
- [20] - Accessory/ STEADICAM attachment
- [21] - Threaded socket and gauged boreholes for CARRYING HANDLE attachment
- [22] - Accessory bracket / RIGHT HANDGRIP attachment
- [25a] - Magazine /Magazine adapter release button
- [26] - Sync out connector

*The CARRYING HANDLE is attached to the threaded socket and gauged boreholes [21] on top of the camera right side; the RIGHT HANDGRIP attachment plate is slid onto the rail [22]. Below the cover plate [18] there is the interface plug for the accessory boxes. The main fuse of the camera (Glass fuse: 6,3 A slow, 5 x 20 mm) is located below the cover plate [17].*

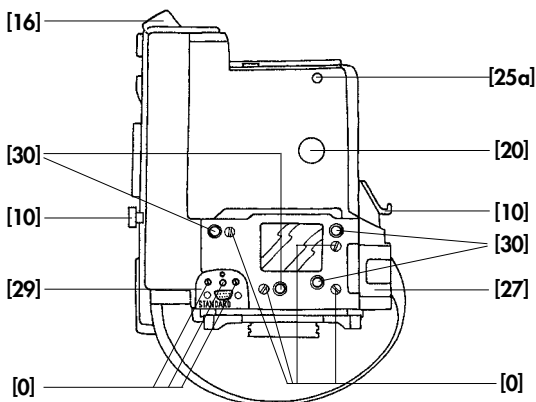

Fig. 6a - CAMERA TOP

- [10] - Tape measure hook
- [16] - Power receptacle
- [20] - Accessory / STEADICAM attachment
- [25a] - Magazine / Magazine adapter release button
- [27] - Assistant work light bracket
- [29] - Engraved viewfinder mounting plate
- [30] - Viewfinder attachment  
(gauged borehole/threaded sockets)
- [0] - Retaining screws

*The plate on top of the camera body shows the format the camera has been adjusted to (either STANDARD 35 or SUPER 35 format).*

*The engraved viewfinder mounting plate [29] is turned upside down when changing the format at a rental house.*





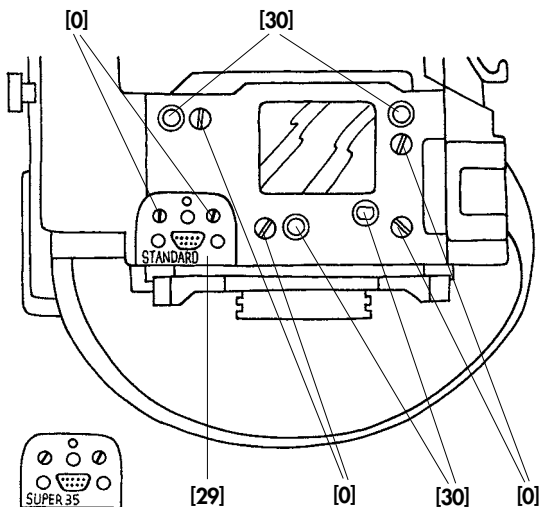

Fig. 6b – VIEWFINDER MOUNT PLATE

The viewfinder systems are attached to the gauged borehole and threaded sockets **[30]** and flanged to the plate **[29]** on top of the glass surface.

**Caution: Do not touch the adjusting and retaining screws [0] - they are reserved for the technicians of the rental house only!**

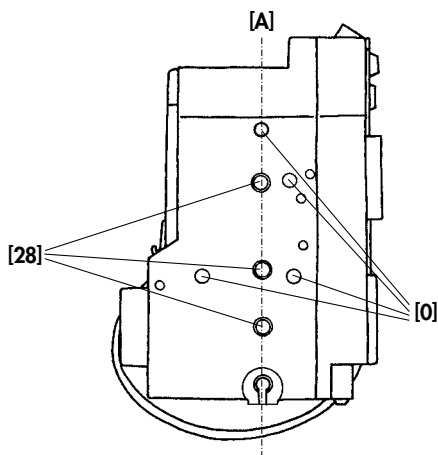

Fig. 7 - CAMERA BASE

- [A] - ARRI axis
- [28] - Threaded sockets
- [0] - Adjusting screws

*Contrary to the other MOVIECAM CAMERAS, the SL has only an ARRI - type axis base.*

**Caution:**

***When working with several camera types, care should be taken that the accessories, e.g. BASE PLATE, MATTE BOX or FOLLOW FOCUS, can be adjusted to the ARRI axis.***

***Do not touch the adjusting screws [0] - they are reserved for the technicians of the rental house only!***

**Notes:**

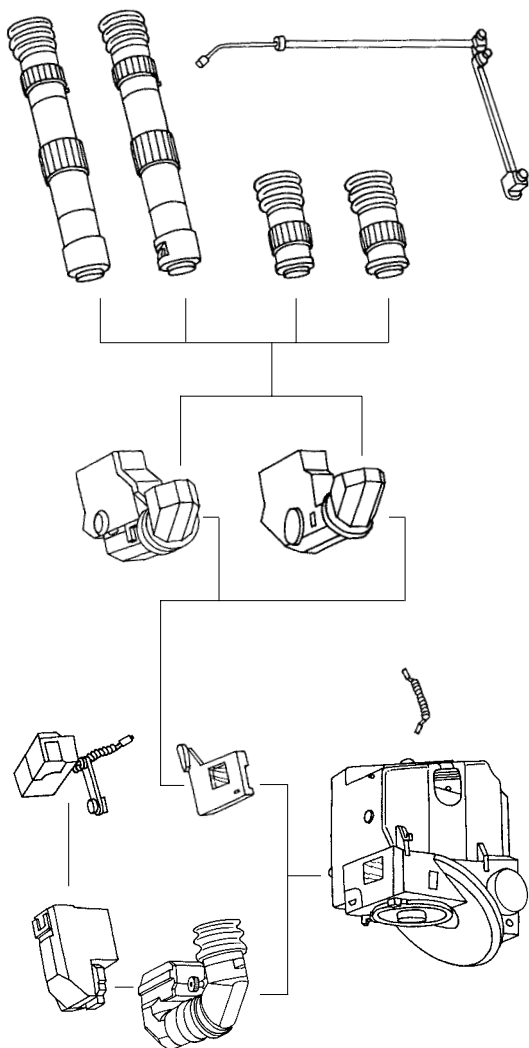

## CHAPTER 2 THE SL OPTICAL- AND THE VIDEO VIEWFINDER

# CHAPTER 2

## SL OPTICAL- AND VIDEO VIEWFINDER

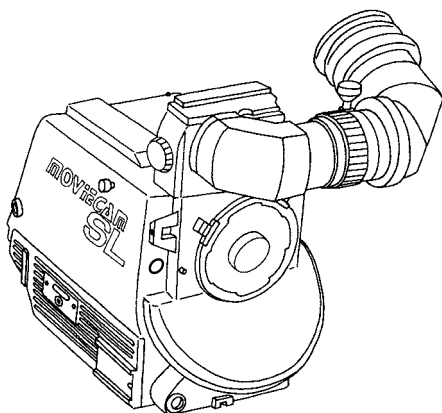

Fig. 8 – THE VIEWFINDERS

*Various viewfinders may be used with the MOVIECAM SL modular system:*

- A) SL OPTICAL VIEWFINDER*
- B) SL VIDEO VIEWFINDER (B&W VIDEO CAMERA)*
- C) All other OPTICAL and VIDEO VIEWFINDERS of the COMPACT SYSTEM*

*A) The SL OPTICAL VIEWFINDER is a lightweight construction with integrated beam splitter. The eyepiece is not interchangeable. It can be rotated 360° only vertically while maintaining an erect image.*

*B) The SL OPTICAL VIEWFINDER permits the use of the SL VIDEO B&W VIDEO CAMERA (mounted on the top). The light transmission ratio of the built-in beam splitter is 80% / 20% (80% light transmission for the eyepiece, 20% for the video camera).* →

C) *By means of the SL ADAPTER PLATE all OPTICAL and VIDEO VIEWFINDERS of the MOVIECAM COMPTACT system may be used with the MOVIECAM SL including VIDEO CAMERAS and VIDEO ASSIST MONITOR, MOVIELITE, REMOTE CONTROL and READOUT systems.*

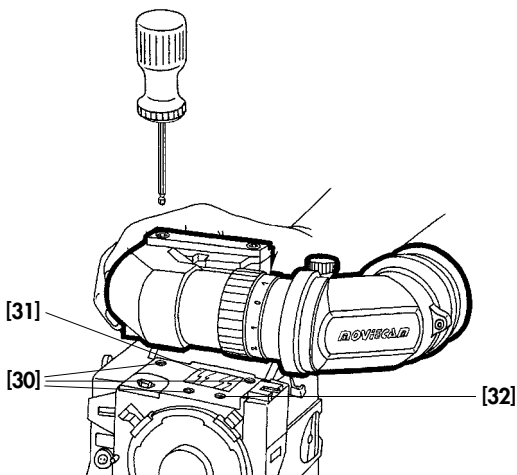

Fig. 9 – MOUNTING THE SL VIEWFINDER

- [30] - Threaded sockets
- [31] - Glass surfaces
- [32] - Gauged borehole

*After removing both caps, the SL OPTICAL VIEWFINDER is mounted to the camera body with three M5 Allen screws.*

**Care should be taken that:**

- 1. the VIEWFINDER sits plane on the mount,*
- 2. the pin engage easily in the gauged borehole and*
- 3. both glass surfaces are absolutely clean.*



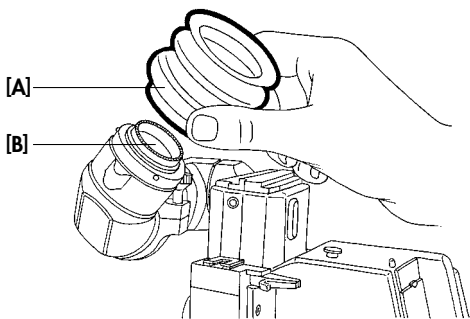

Fig. 10 – EYECUP

The eyepiece has an interchangeable RUBBER EYECUP **[A]**. To clean the exit pupil **[B]**, remove the EYECUP by simply pulling it straight out.

Eye-friendly covers, such as chamois or cotton cloth, can be easily attached with a rubber band. Another useful cover are the terry cloth "wrist bands", well-known from tennis, as they are sweat-absorbing, reusable and easy to attach.

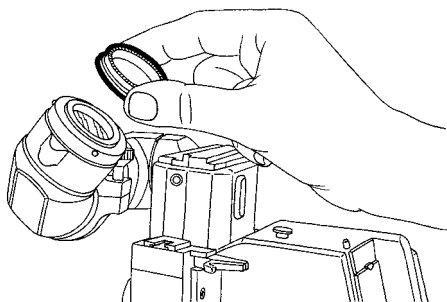

Fig. 11 – EYECUP RETAINING MOUNT

Below the RUBBER EYECUP there is a magnetically held ATTACHMENT RING for a diopter correction lens or some special filter.

Lens or filter must have a diameter of 31,5 mm.

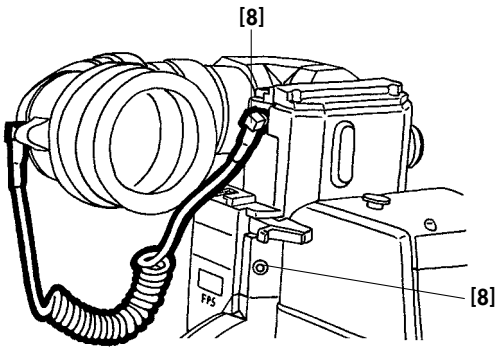

Fig. 12 – EYECUP HEATER

*A heated eyecup, which eliminates fogging of the exit pupil, is integrated in the eyepiece of the MOVIECAM SL.*

*There is no on/off switch for the eyecup heater; in order to activate it, disconnect the camera, plug one end of the short coiled cable into the eyepiece connector, the other end into one of the connectors [8]. Connectors on camera and eyepiece are identical.*

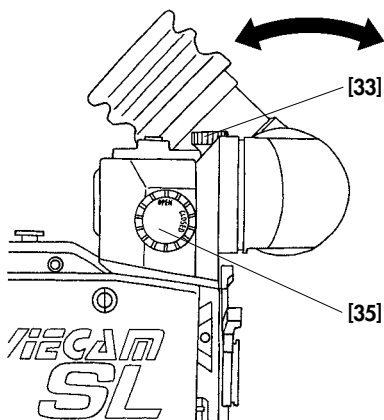

Fig. 13 – FRICTION ADJUSTMENT OF THE PIVOTING EYEPIECE/EYEPIECE SHUTTER WHEEL

The eyepiece is integrated into the SL OPTICAL VIEWFINDER and rotatable by 360°. It automatically gives an upright erect image, regardless of the angle of view.

To swing the eyepiece, loosen the tension screw **[33]** below the eyepiece mount, move the eyepiece and tighten the screw again.

To loosen tension brake, turn counter-clockwise.  
To tighten tension brake, turn clockwise.

An integrated eyepiece shutter wheel **[35]** can be set to two different positions:

- 1) "OPEN"
- 2) "CLOSE"

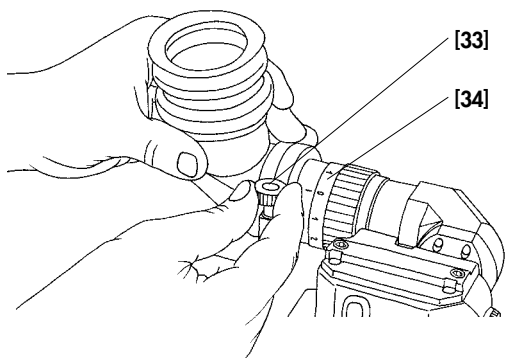
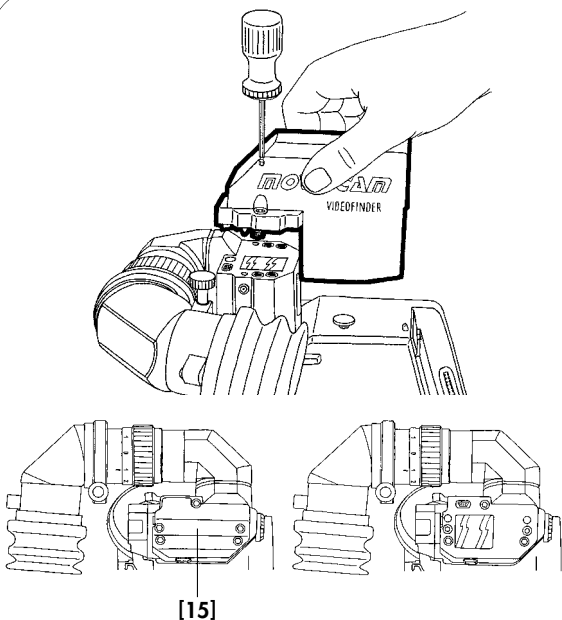

Fig. 14 – DIOPTER CORRECTION

The MOVIECAM SL eyepiece may be diopter-adjusted by turning the knurled barrel [34].

With the help of a scale, where personal marks may be added, the assistant can easily adjust the eyepiece to the eyesights of the different people using the camera. Corrections can be made from -5 to +5 diopters.



— Fig. 15a + 15b – SL B&W VIDEO CAMERA —

*An SL B&W VIDEO CAMERA can be attached to the SL OPTICAL VIEWFINDER.*

*At the top side of the SL OPTICAL VIEWFINDER, below a cover [15], there is the exit pupil for the video image and a small connector for the power supply of the VIDEO CAMERA. Always attach the cover to the OPTICAL VIEWFINDER (with two M5 Allen screws) when no VIDEO CAMERA is installed.*

*The VIDEO CAMERA has a similar cover.*

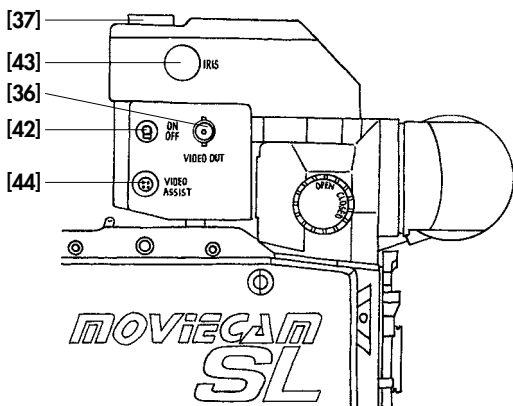

Fig. 16 – THE SL B&W VIDEO CAMERA

- [42] - On/off switch
- [43] - rotary (iris) knob
- [44] - "Fischer" connector for video assist monitor
- [36] - BNC video outlet
- [37] - attachment for the video assist monitor.

*The SL B&W VIDEO CAMERA is provided with an attachment and a connector for a small on-board video assist MONITOR.*

*At the right side of the B&W VIDEO CAMERA there is a BNC video outlet to connect various devices, e.g. monitors, recorders or transmitters.*

**Caution: When a device is connected, care should be taken that no tension is exerted on the camera - otherwise the connector and thus the video camera and the MOVIECAM SL itself might be damaged!**

*The cables should not restrict the operator's mobility.*

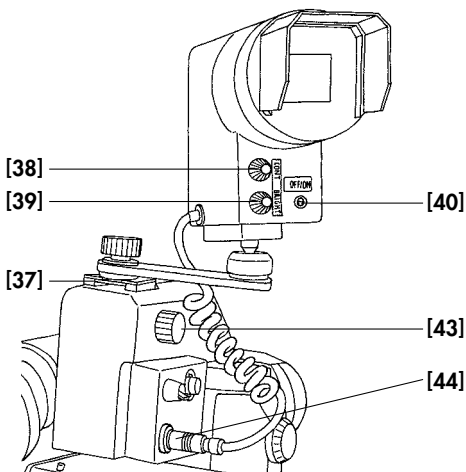

Fig. 17 – THE B&W VIDEO ASSIST MONITOR

By adjusting the mechanical iris of the video camera lens with the rotary knob [43], the video picture is adapted to the brightness of the ground glass image. Mount the small B&W VIDEO ASSIST MONITOR by sliding its rotatable arm onto the accessory brackets [37] on top of the VIDEO CAMERA.

Connect it to its "Fischer" outlet [44].

**Caution: Protect the small B&W monitor tube against strong lights (e.g. strong luminaires in frame) – it might get damaged!**

Adjust contrast and brightness with the two small knobs [38+39] on the front. Standard defaults should only be changed if necessary.

**Caution: Adjust video iris only after lens aperture of the MOVIECAM SL has been set!**

In case the monitor is not needed, it can be turned off with a small switch [40].

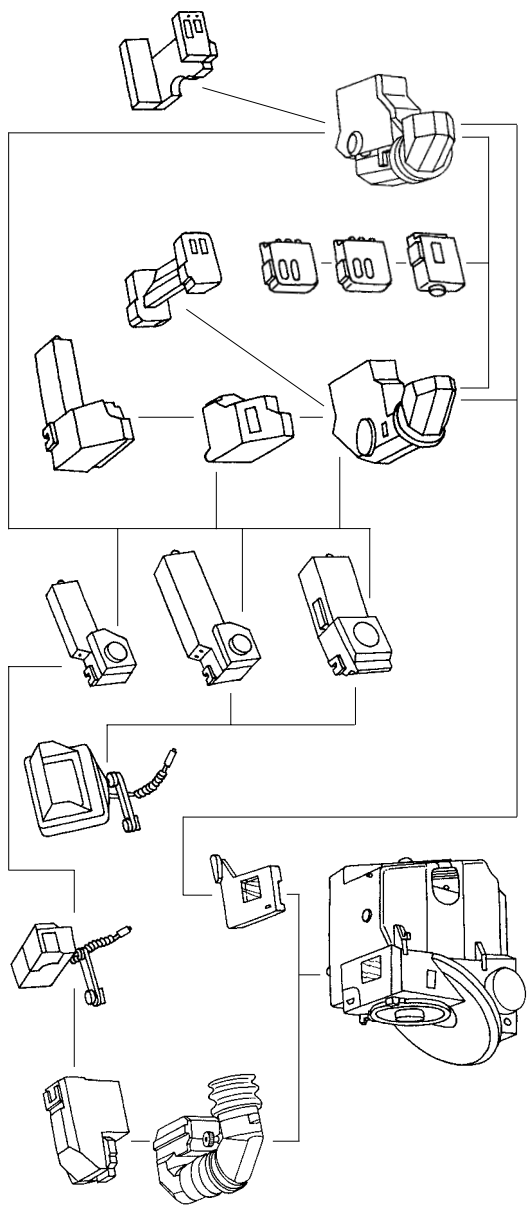

CHAPTER 3  
THE VIEWFINDER ADAPTER PLATE  
AND THE COMPACT VIEWFINDERS



# CHAPTER 3

THE VIEWFINDER ADAPTER  
PLATE AND THE SL  
VIEWFINDERS

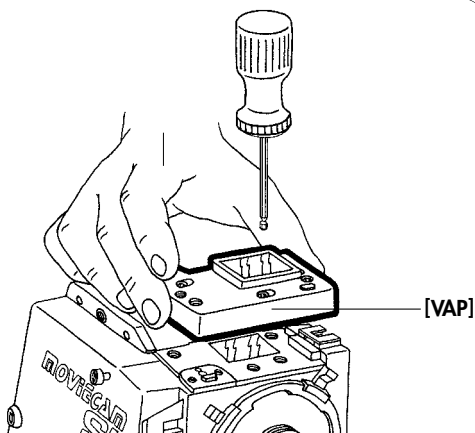

Fig. 18 – THE VIEWFINDER ADAPTER PLATE

As already mentioned in our Preface, the SL CAMERA is compatible with most parts of the COMPACT system. Two SL ADAPTERS are provided. With the first one, the COMPACT viewfinder systems can be used on the SL; with the other SL ADAPTER, the COMPACT MAGAZINES can be used.

The VIEWFINDER ADAPTER PLATE **[VAP]** is a small plate with an optical system that is attached to the camera body like the SL OPTICAL VIEWFINDER. On this plate, any COMPACT OPTICAL or VIDEO VIEWFINDER as well as the accessories, such as MOVIELITES, READOUTS and REMOTE CONTROL, may be attached. The VIDEO CAMERAS (B&W or color) may also be attached to the COMPACT VIEWFINDERS. You may fix e.g. the B&W VIDEO CAMERA onto the VIEWFINDER ADAPTER PLATE of the MOVIECAM SL for remote or STEADICAM operation or the ORIENTABLE VIEWFINDER with LONG EYEPIECE for studio operation.



*For detailed information about all these parts, please consult the COMPACT USERS GUIDE.*

**Caution:**

***Before mounting the adapter plate, make sure that all glass surfaces are meticulously clean.***

***Care should be taken that the adapter sits plane on the camera body.***

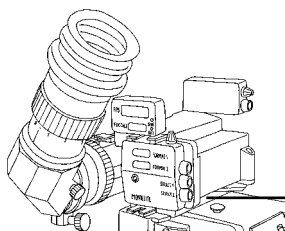
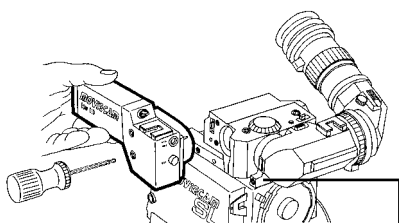

[VAP]

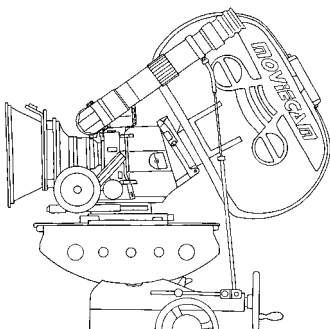

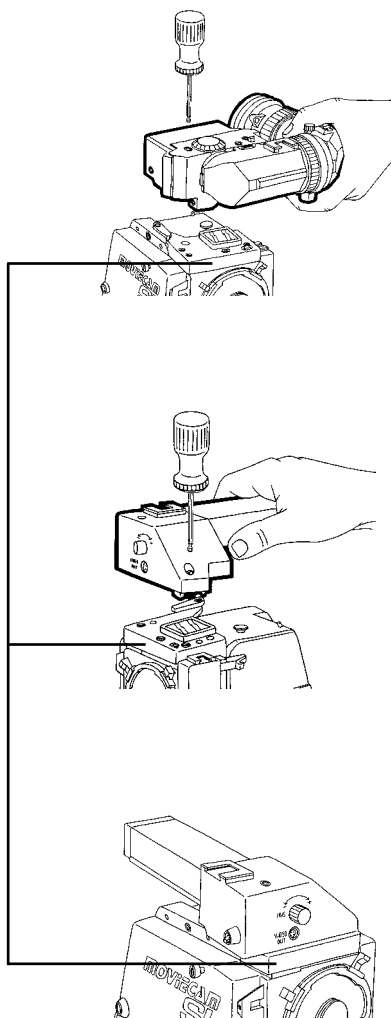

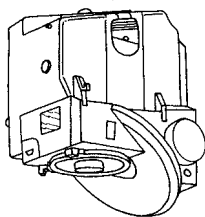
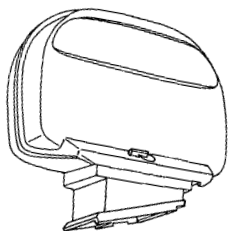
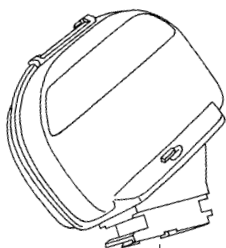

CHAPTER 4  
THE SL MAGAZINES

# CHAPTER 4

## THE SL MAGAZINES

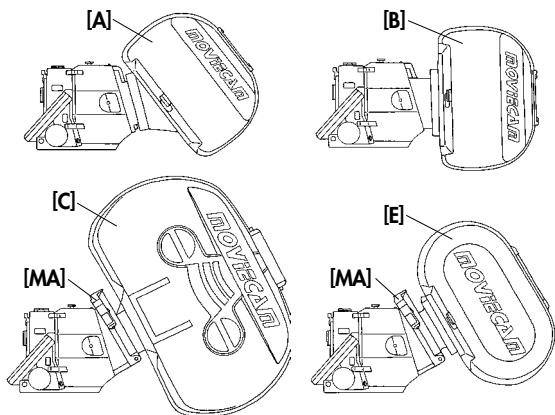

Fig. 19 – THE MAGAZINES

*MOVIECAM offers two magazines for the SL:*

- [A]** 400 ft / 120 m LIGHTWEIGHT MAGAZINE for shoulder operation
- [B]** 400 ft / 120 m LIGHTWEIGHT MAGAZINE for STEADICAM operation

*Both magazines are extremely light and minimum sized.*

**Caution: There is one important difference to the other magazines of the MOVIECAM family: with the SL MAGAZINES, it is not possible to shoot reverse.**

*With a SL MAGAZINE ADAPTER [MA], you may use the following magazines of the COMPACT system on the MOVIECAM SL (for shooting in both directions):*

- [C]** 1.000 ft / 300 m LIGHTWEIGHT MAGAZINE
- [D]** 1.000 ft / 300 m MAGAZINE
- [E]** 500 ft / 150 m LIGHTWEIGHT MAGAZINE
- [F]** 500 ft / 150 m MAGAZINE
- [G]** 400 ft / 120 m LIGHTWEIGHT MAGAZINE for STEADYCAM operation.

*For more information about those magazines, please consult the COMPACT USERS GUIDE.*



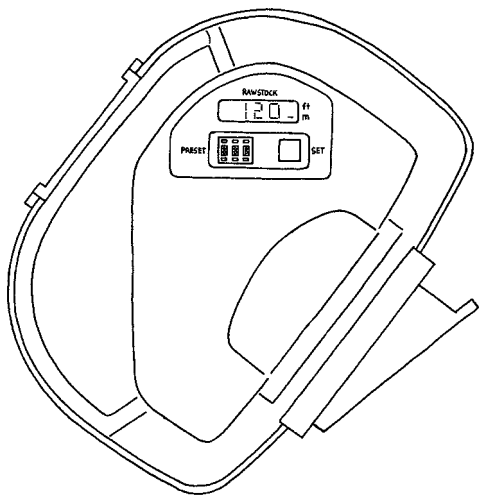

Fig. 20 – THE SL MAGAZINES

*The digital footage counter displays the remaining footage; it is powered by its own on-board battery. When a magazine is attached to a powered camera, the magazine battery recharges automatically. In case nothing is displayed (which very rarely happens), simply mount the magazine to a powered camera in order to load the on-board battery and to reactivate the display. The magazine battery usually recharges automatically during the shooting period.*

*After loading the magazine, use the "preset buttons" to input the length of film loaded.*

*By pressing the "set button", the footage counter stores the input. It counts backward when the camera is running.*

*The "raw stock" display shows the length of remaining unexposed film.*



Fig. 21 – THE SL MAGAZINES

The small lock lever [A] is, when locked, secured by a spring steel safety tab [B].

Open the magazines by pressing the safety tab down and turning the lever counter-clockwise. When closing, the safety tab automatically prevents an unintended opening.

**Caution: Do not twist the safety tab!**

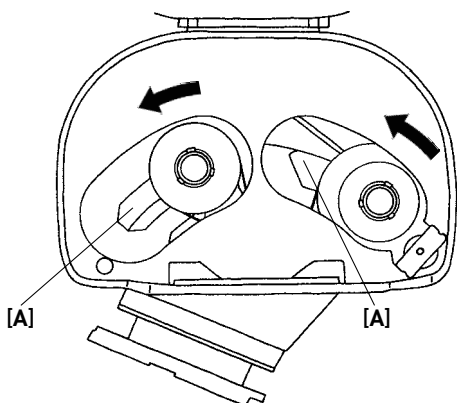

Fig. 22a – SL MAGAZINE INTERIOR

*The construction of these magazines was based on two important aspects: size and weight.*

*Regarding the size, these magazines were built as active displacement - type magazines. This means the take-up core continuously shifts from its start position towards the feed core, while the feed core itself shifts backward.*

*Regarding the weight, these brand-new magazines were made out of a carbon compound.*

*Compared with aluminium magazines, this means less weight but still the same stiffness and acoustic properties.*

*Even though the magazines have torque motors, heaters and digital footage counters, they are still very lightweight and thus ideal for shoulder or STEADICAM operation.*

*The core holders are mounted mobile to allow an active displacement. Be sure that no dust enters the two openings [A] at the bottom of the magazine.*

*The core holders are identical with those of the other magazines described in the MOVIECAM COMPACT or SUPERAMERICA USERS GUIDES.*

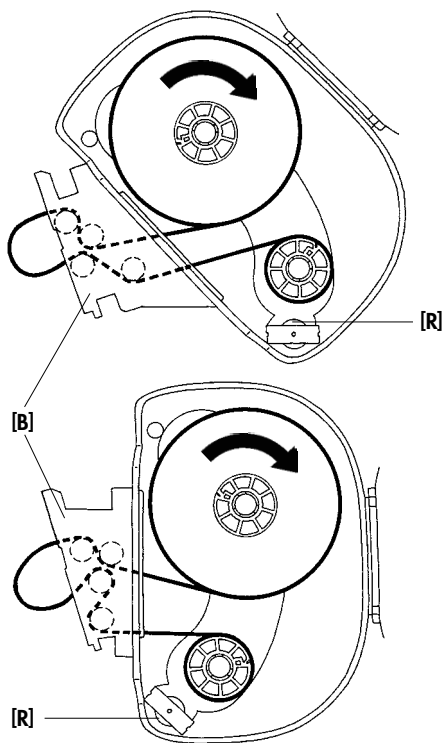

Fig. 22b – SL MAGAZINES INTERIOR

The difference between these two magazines is the design of the light-traps **[B]** in which the roller assemblies are mounted. The STEADICAM magazine mount is designed in such a way that, throughout shooting the 400 ft / 120 m film, the center of gravity is maintained.

**Important:** As soon as film is wound onto the take-up core, the core will automatically be moved toward the feed core. For this reason it is essential that the small roll **[R]** is rotating easily.

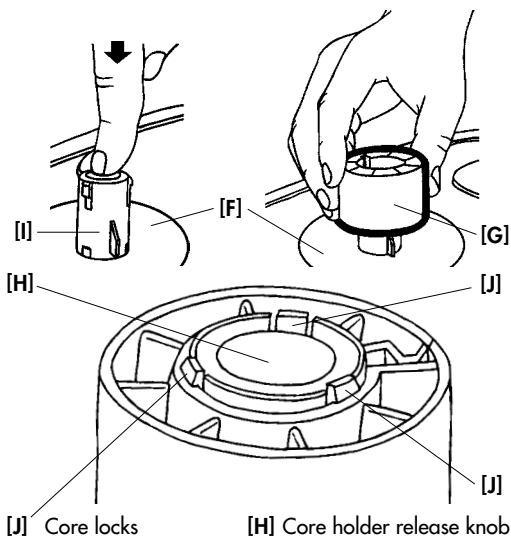

Fig. 23a – LOADING THE LIGHTWEIGHT SL MAGAZINES

- 1) Clean darkroom / changing bag.
- 2) Lay the magazine down carefully onto footage counter side; roller assembly is facing you.
- 3) Lift magazine cover.
- 4) Check and clean magazine.  
 Now put a core **[G]** on the film plate **[F]** until you hear a first "click". Hold the plate and – simultaneously – turn the core gently to the left or right until you hear a second "click". **Only now** the core is properly seated. In case you do not hear the "clicks", the core holder **[H]** pin has →

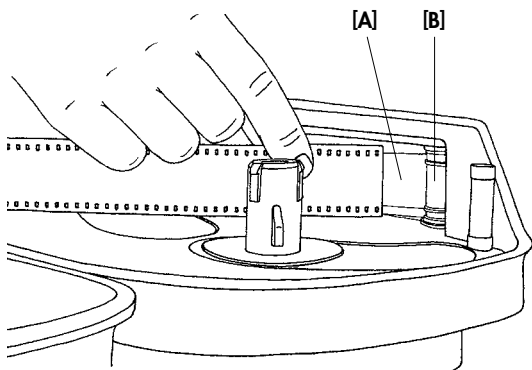

Fig. 23b – LOADING THE LIGHTWEIGHT SL MAGAZINES

engaged in the hole of the core already at the beginning. It is **not** properly seated – have another try. Locked cores are released by pressing the release knob **[H]** on core holder. Checking core holders **[I]** and core locks **[J]**: By pressing the release knob **[H]** on top of the core holder, the three core locks move inward.

**Caution: In case of a malfunction of the core holder, do not disassemble – magazines should be serviced at a MOVIECAM Rental House.**

**From now on in darkness:**

- 5) Put film roll on empty can and place it to the magazine left side.
- 6) Wind off just enough film to insert it in the roller assembly. Gently push the film into the slot between rail **[A]** and roller **[B]** until it emerges from the other side. →

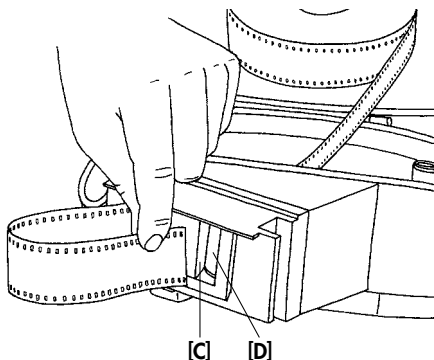
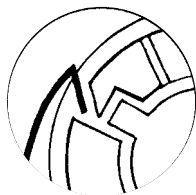
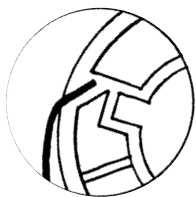
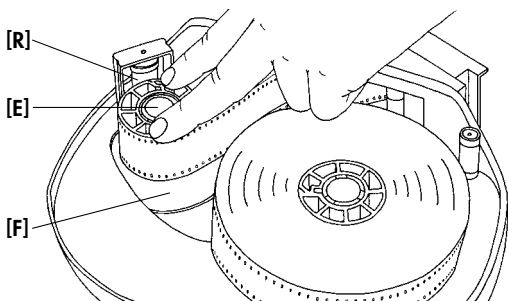

Fig. 23c – LOADING THE LIGHTWEIGHT SL MAGAZINES

- 7) Pull approx. 50 cm film toward you. Unlock the left core holder by depressing the release knob **[H]**. Place film roll onto core holder - do **not** press toward magazine bottom (caution - film might be scratched!). Because of the displacement mechanism, great care must be taken that the film rolls on both sides are absolutely flatly wound.
- 8) Insert film from outside into magazine between magazine nose **[C]** in roller assembly and right roller **[D]**.
- 9) Feed film into core slot so that no acute angle forms when turning the core clockwise (See page 56 Fig. 23d). Wind just enough film around take-up core to make sure it will not accidentally slide out again. Wound-up film has to be flush with the core and lie flat on the small take-up plate **[F]**. Make sure that the film is not wound up below the recess of the small roller **[R]**. The film windings on the feed side must not protrude **below** plate – film might touch the magazine bottom. →



WRONG WAY

Fig. 23d – CORE HOLDER

10) Close and latch magazine after checking that film is properly seated.

**Caution:** When closing the magazine, care should be taken that nothing (e.g. changing bag, film bag etc.) is caught between magazine cover and base.

**When the light is on again:**

11) Attach a loop protector and

12) Feed length of unexposed film into footage counter.



**Notes:**

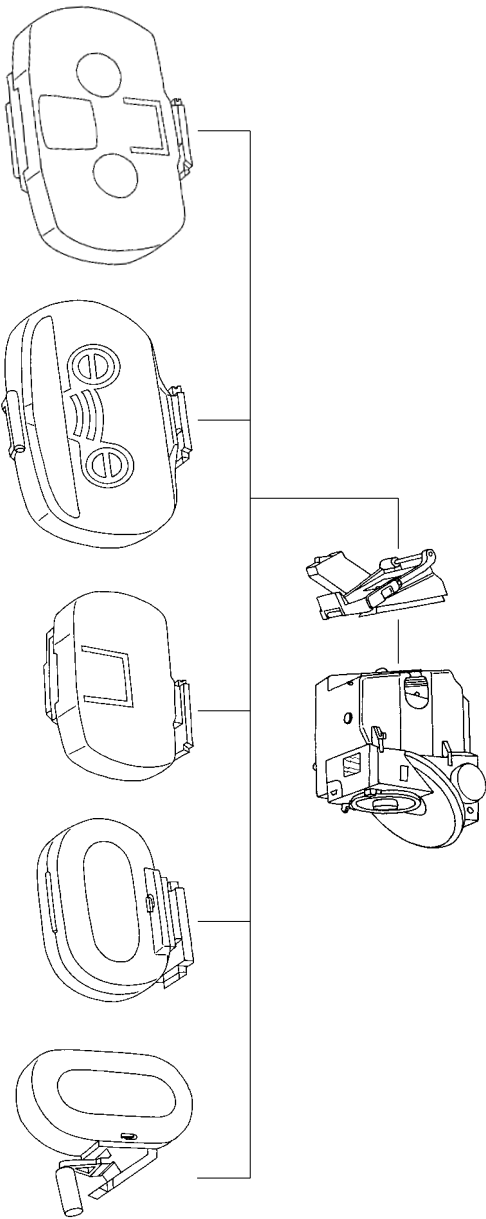

CHAPTER 5  
THE SL MAGAZINE ADAPTER

# CHAPTER 5

## THE SL MAGAZINE ADAPTER

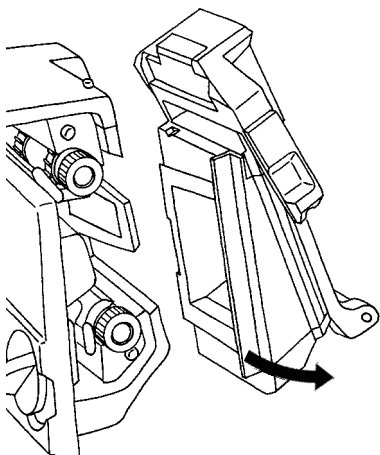

Fig. 24 – THE SL MAGAZINE ADAPTER

*In order to mount the magazines from the COMPACT system, MOVIECAM offers an SL MAGAZINE ADAPTER that simulates the COMPACT camera opening. To mount this ADAPTER to the SL body, you have to slit it onto the rail, like an SL MAGAZINE itself. Slide the SL MAGAZINE ADAPTER onto the rails carefully until you hear a "click" and the adapter sits tight.*

*The other side of the ADAPTER is similar to the magazine receptacle of the COMPACT TOP MOUNT ADAPTER.*

*The left side of the SL MAGAZINE ADAPTER can be opened, which makes threading the film easier. For information about the mentioned TOP MOUNT ADAPTER and the other compatible MOVIECAM MAGAZINES, please consult the COMPACT USERS GUIDE.*

**Notes:**

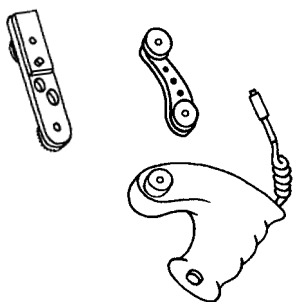
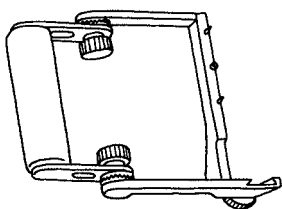
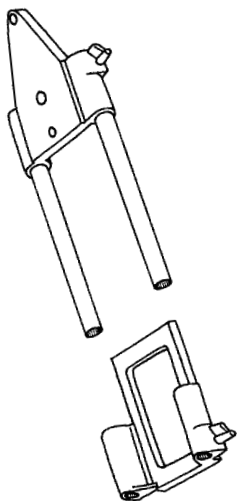

CHAPTER 6  
THE SL CARRYING HANDLE AND HANDGRIPS

# CHAPTER 6

## THE SL CARRYING HANDLE AND HANDGRIPS

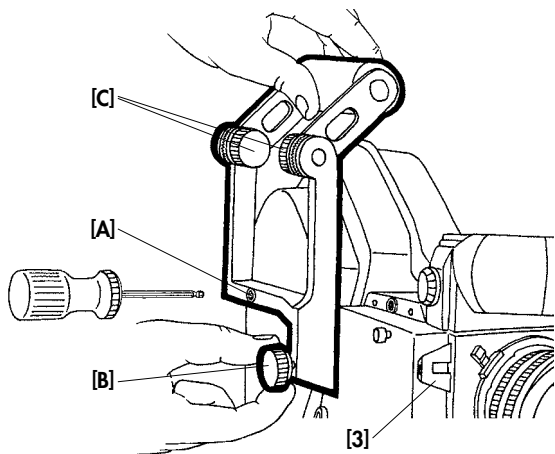

Fig. 25 – THE CARRYING HANDLE

The SL CARRYING HANDLE is mounted onto the accessory dovetail bracket [3] and fixed with two screws. One screw [A] is tightened with an M5 Allen screwdriver, the other by turning the knurled knob [B].

Make sure to mount the carrying handle firmly and properly.

With the two knurled knobs [C], you may change the position of the carrying handle.

The actual SL CARRYING HANDLE is only designed to carry the camera equipped with the SL OPTICAL VIEWFINDER. Other CARRYING HANDLES will soon be designed for the SL equipped with other Viewfinders.



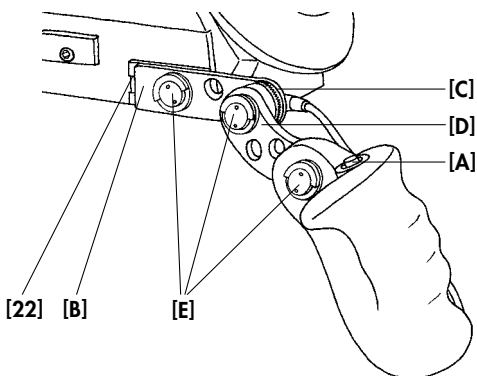

Fig. 26 – THE RIGHT HANDGRIP

For handheld operation, MOVIECAM offers an ergonomically designed RIGHT HANDGRIP with built-in on/off button **[A]**. This button works like an “alternating switch”: you can switch on the camera with the handgrip button and switch it off with the other one **[7]** on the camera left side and vice versa. The RIGHT HANDGRIP is fixed to the MOVIECAM SL by means of a small MOUNTING RAIL **[B]**. The mounting rail is slid onto the handgrip attachment **[22]** of the camera and has a rosette with screw whose mobile latch permits easier handling. Due to the rosette joint **[C]**, the RIGHT HANDGRIP may be attached firmly at any vertical angle.

A further accessory is the RIGHT HANDGRIP EXTENSION **[D]** that permits to adjust the handgrip position ergonomically. This extension facilitates the simultaneous use of the RIGHT HANDGRIP and STUDIO FOLLOW FOCUS.

Do not forget to tighten the screws **[E]** and to connect the handgrip plug to the on/off button outlet ( Fig.2) **[1]**.

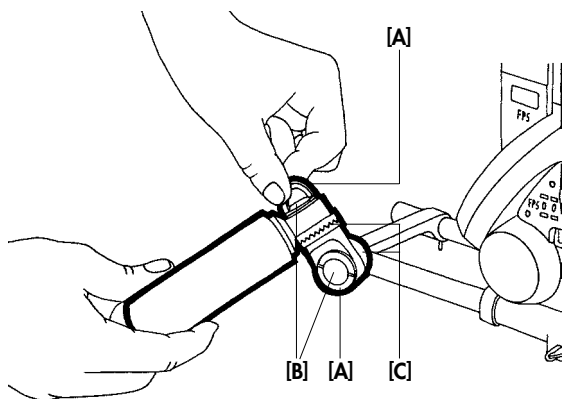

Fig. 27 – THE LEFT HANDGRIP

*MOVIECAM provides an additional handgrip for the camera left side that can be turned in any direction. Slide the handgrip onto the support rods and tighten at both sides. To change the handgrip position, lift both latches **[A]** and loosen the screws **[B]**.*

*In the desired position, tighten the screws in both rosette joints **[C]** and put the latches down again.*

**Caution: The LEFT HANDGRIP is only an additional support - do not use as carrying handle (one-sided strain!).**

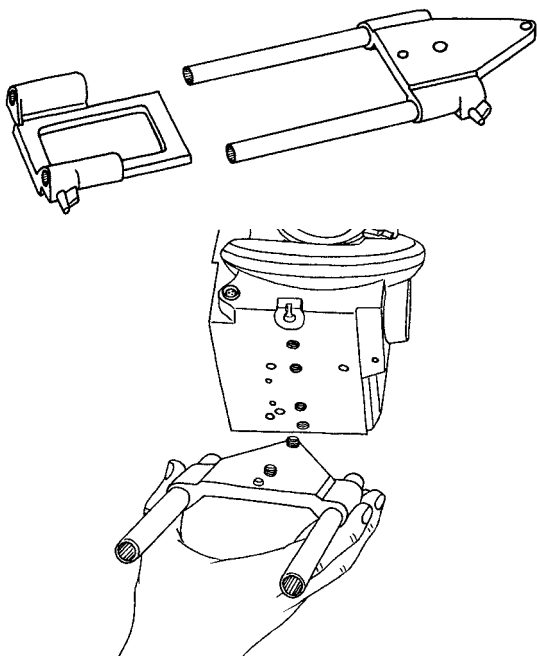

Fig. 28 – THE SL LIGHTWEIGHT BASE PLATE

*An extremely lightweight SL BASE PLATE has been designed for hand held operation with the MOVIECAM SL.*

*This base plate consists of two parts:*

*One part is attached to the camera, the other to the camera head. To attach the camera to the camera head, simply slide the plate rods into their counterparts.*

**Caution: This base plate is available only for the Standard 35 configuration.**

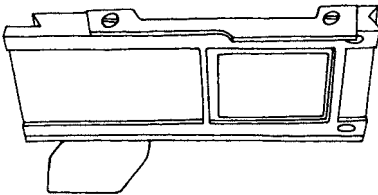
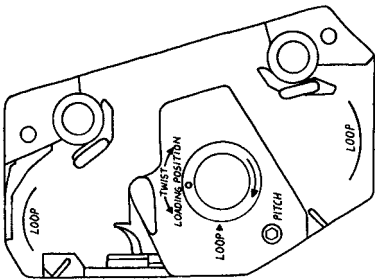
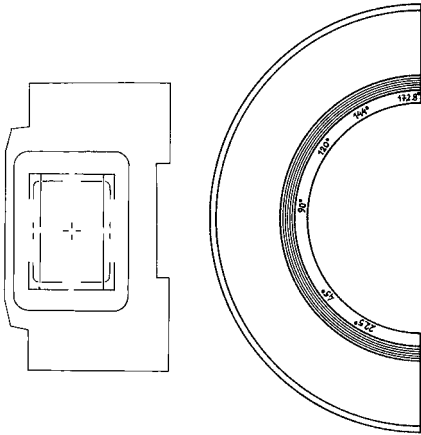

CHAPTER 7  
THE INTERIOR OF THE SL

# CHAPTER 7

## THE INTERIOR OF THE SL

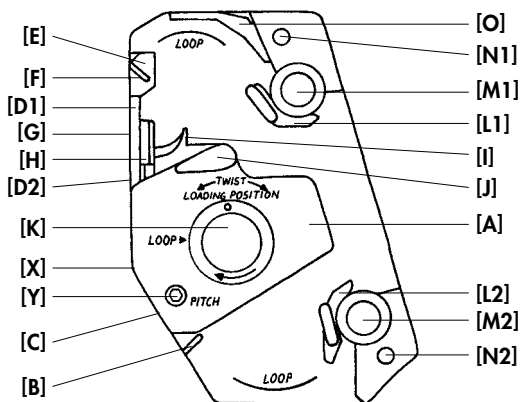

Fig. 29 - THE SL INTERIOR

- [A] Movement block
- [B] Lock lever for lower aperture plate
- [C] Lower aperture plate
- [D1] Upper aperture plate
- [D2] Gate
- [E] Handle of upper aperture plate
- [F] Lock lever for upper aperture plate
- [G] Front film guide
- [H] Pressure plate
- [I] Pressure block
- [J] Lever of movement block
- [K] Inching knob
- [L1] Upper rear film guide
- [L2] Lower rear film guide
- [M1] Upper sprocket
- [M2] Lower sprocket
- [N1] Release knob for upper rear film guide
- [N2] Release knob for lower rear film guide
- [O] Buckle switch
- [X] Mounting rail for aperture plates (hided)
- [Y] Pitch adjustment screw

*In order to adjust the movement to the properties and dimensions of the film material in use and at the same time achieve an even more quiet and gentle film transport, a pitch adjustment control has been built into the movement block of the SL.*

*The pitch adjustment screw **[Y]** has no marks and no buffer stop; the adjusting range is a whole turn of the screw.*

*While the camera runs with normal frame speed (24 - 25 fps) and the material to be used, with an M5 Allen screwdriver, by slowly turning clockwise or counter-clockwise, the position is looked for in which the camera runs most smoothly and quiet. This position is just a small segment of a screw turn.*

**Remark:**

*The interior of the SL looks similar to that of the other MOVIECAM cameras, but the rear film guides and the rear buckle switches are mounted differently. Both rear film guides can be opened by pressing the release knobs **[N1, N2]** or closed by pushing the guides towards the sprocket wheels. Notice that the upper wheel has, contrary to the one of the MOVIECAM COMPACT, two rows of sprockets.*

*The movement block and other parts, like the LOWER APERTURE PLATE, the GROUND GLASSES, the mirror shutter etc. are identical with those of the MOVIECAM COMPACT.*

*The description of those parts can be found in the COMPACT USERS GUIDE.*

*The UPPER APERTURE PLATE (gate) as well as the PRESSURE PLATE of the SL have newly designed grips – **they are not compatible with other MOVIECAM cameras.***

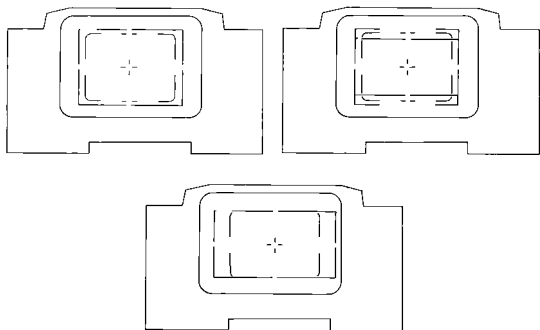

Fig. 30 – GROUND GLASSES

*The SL is equipped with the same GROUND GLASSES as the other MOVIECAM cameras. GROUND GLASSES with the following markings are available:*

**STANDARD 35 formats:**

- 1 : 1.375 (Academy)
- 1 : 1.375 + TV
- 1 : 1.375 (camera + projector)
- 1 : 1.375 + 1 : 1.66
- 1 : 1.375 + 1 : 1.75
- 1 : 1.375 + 1 : 1.85
- 1 : 1.66
- 1 : 1.66 (camera + projector)
- 1 : 1.66 + TV
- 1 : 1.66 + 1 : 1.85
- 1 : 1.78 (HDTV)
- 1 : 1.85
- 1 : 1.85 (camera + projector)
- 1 : 1.85 + TV
- 1 : 2.35 (scope)

**SUPER 35 formats:**

- Superscope 35
- Superscope 35 (camera + projector)
- Superscope 35 + TV
- Super 1 : 1.85
- Super 1 : 1.85 + TV



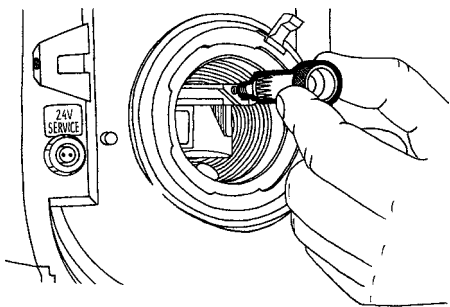

Fig. 31a – CHANGING THE  
GROUND GLASSES

The ground glass of the MOVIECAM SL lies flat on top of the mirror shutter and has a metal holder with a thread in the right front corner. Use the MOVIECAM COMBITOOL **[T4]** to exchange the ground glass as follows:

1. **Disconnect the camera**
2. Remove lens or cavity cap.
3. Open the camera door. Turn the inching button **[K]** to clear the mirror shutter out of the way.
4. Screw the MOVIECAM COMBITOOL into the GROUND GLASS metal holder. →

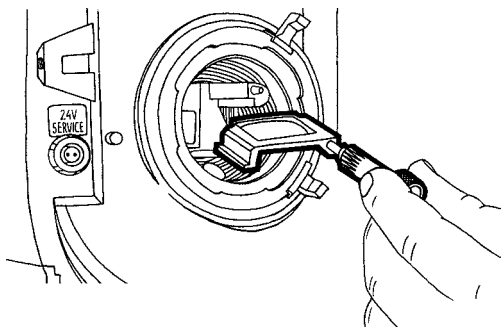

Fig. 31b – CHANGING THE  
GROUND GLASSES

When the COMBITOOL sits tight, pull out the ground glass **gently**.

5. Clean the GROUND GLASS gently with a very soft brush or a vacuum cleaner.

**Caution: Do not touch with fingers or a solid object! Do not moisten or wipe!**

6. When screwing the COMBITOOL in or out, hold the ground glass **holder** only.
7. Push the GROUND GLASS **gently** all the way in until it rests against the stop and unscrew the COMBITOOL.

**Caution: Never place the ground glass on its edges. Do not force!**

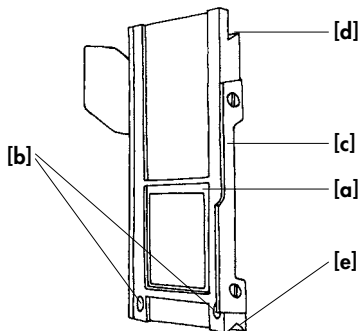

Fig. 32 – UPPER APERTURE PLATE

*Film Gate with Gate Matte is integrated in the UPPER APERTURE PLATE.*

*Four UPPER APERTURE PLATES are available:*

*1 : 1.33 Full aperture*

*1 : 1.375 Academy*

*1 : 1.66*

*1 : 1.85*

*These aperture plates are made of extremely hard material; the film touches the plate only in the perforation area. To avoid deposits, e.g. hair or film dust, the fine Gate Matte **[a]** in the aperture plate is slightly recessed. The openings **[b]** for the registration pins are located left and right of the gate. A guide rail **[c]** is attached to the aperture plate right side. Clean the aperture plate carefully and regularly - best with a vacuum cleaner. Only when it is badly smudged – which will rarely be the case when handled properly and carefully – should you clean it with a small brush or an orangewood stick.*

**Caution:**

**Never ever lubricate the aperture plate!**



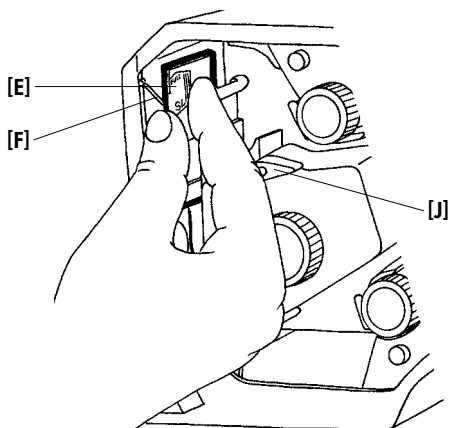

Fig. 33a – MOUNTING OF THE UPPER APERTURE PLATE

The image plane is located between the UPPER APERTURE PLATE and the PRESSURE PLATE. Both aperture plates (upper and lower) are attached to notched brackets. For mounting, the UPPER APERTURE PLATE has V-shaped notches at its top **[d]** and bottom **[e]** edges. These notches must be absolutely clean to make sure the aperture plate can be seated properly. The V-shaped bottom edge of the UPPER APERTURE PLATE, seated on the rail **[x]**, is held by a spring loaded lever. When removing the UPPER APERTURE PLATE,

1. push back the movement by turning lever **[J]** clockwise,
2. lift the small lever **[F]** and pull out UPPER APERTURE PLATE by its handle **[E]**.

**Caution: Be careful not to damage aperture plate or gate - this might have serious consequences!**



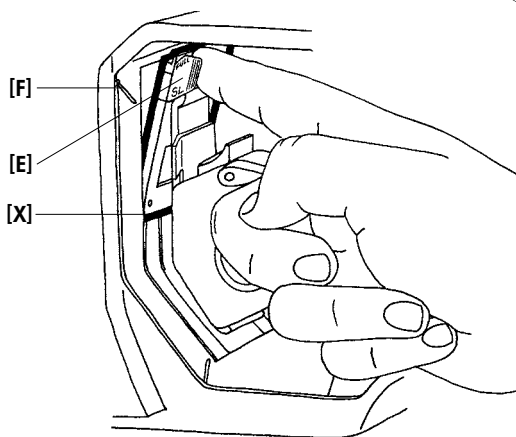

Fig. 33b – MOUNTING OF THE UPPER APERTURE PLATE

Insert the UPPER APERTURE PLATE on the rail **[X]** and press forward gently while lifting the small lever **[F]** and bringing it back to its resting position (= lock) again. You can insert the aperture plate only parallel to the rail **[X]**!

**Caution:** In case the aperture plate is slanting, start inserting again.

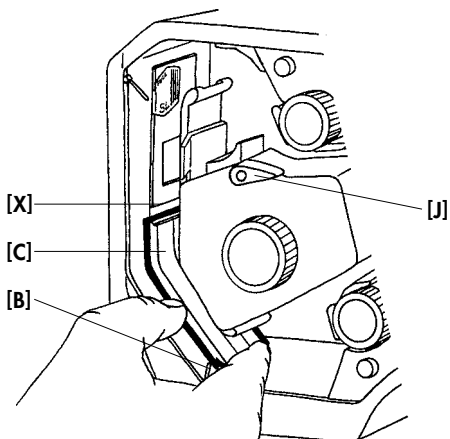

Fig. 34 – LOWER APERTURE PLATE

*Like the upper plate, the lower one also has V-shaped notches at its top and bottom edges. The LOWER APERTURE PLATE has two slots for the pulldown claws. Notches, slots and surface of the aperture plate must always be clean – check regularly. Like the UPPER APERTURE PLATE, the lower plate is attached to notched brackets.*

*When removing the LOWER APERTURE PLATE,*

- 1. slide back the movement block by turning lever **[J]**;*
- 2. press the small lever **[B]** down;*
- 3. hold the released aperture plate **[C]** at its base and remove it.*



To insert the LOWER APERTURE PLATE, follow the steps described below:

1. Insert the LOWER APERTURE PLATE in the camera below the movement block;
2. pull LOWER APERTURE PLATE up and swing slightly toward camera front until it touches the rail **[X]**.
3. Simultaneously, pull down the small lever **[B]** and press the lower part of the aperture plate in.
4. Lock the LOWER APERTURE PLATE in the camera by releasing the spring loaded lever **[B]**.

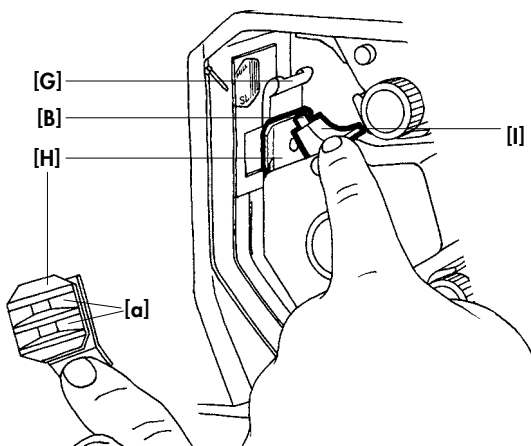

Fig. 35 – PRESSURE PLATE

In the front center of the front film guide **[G]**, there is an opening for the PRESSURE PLATE **[H]**. This plate has two raised surfaces **[a]** that hold the film in the gate plane with a spring loaded pin. Smudged surfaces inevitably cause film scratches! To clean the pressure plate, remove it as described below:

1. Swing the pressure block **[I]** backward.
2. Lift and remove the pressure plate.
3. Check PRESSURE PLATE and both surfaces thoroughly and - if necessary - clean them with lint-free cloth or orangewood sticks. Clean also the cavity at the rear of the pressure plate.

The spring is pressed into this cavity. The spring loaded steel pin **[B]** in the pressure block presses the plate onto the film with a certain force. When tapped lightly, the pin should move easily and spring back to its former position.



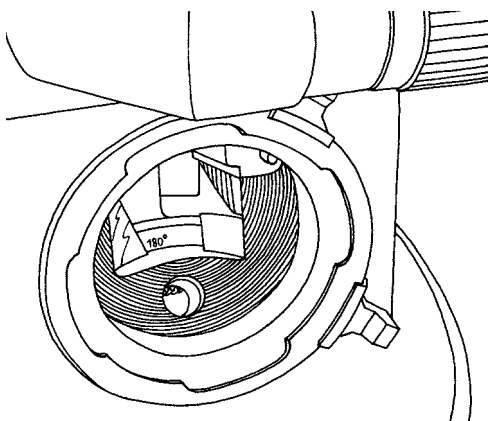

Fig. 36a – MIRROR SHUTTER

*The opening angle of the mirror shutter ranges from 22,5° to 180°. To check or adjust the mirror shutter angle, proceed as follows:*

- 1. Important: disconnect the camera.**
- 2. Remove lens or cavity cap and open the camera door.* →

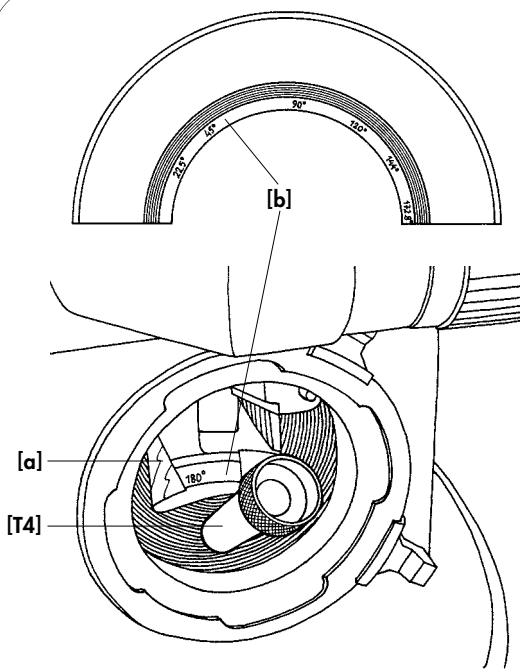

Fig. 36b – MIRROR SHUTTER

3. Advance mirror shutter **[a]** with inching knob **[K]** until shutter angle mark **[b]** is visible in the lens mount.

4. Insert the MOVIECAM COMBITOOL **[T4]** in the small opening below this mark and turn it until you get the desired mirror shutter angle marked on the scale **[b]**.

The mirror shutter has six positive stops for the following shutter angles:

22,5°, 45°, 90°, 120°, 144°, 172.8°, 180°.

**Notes:**

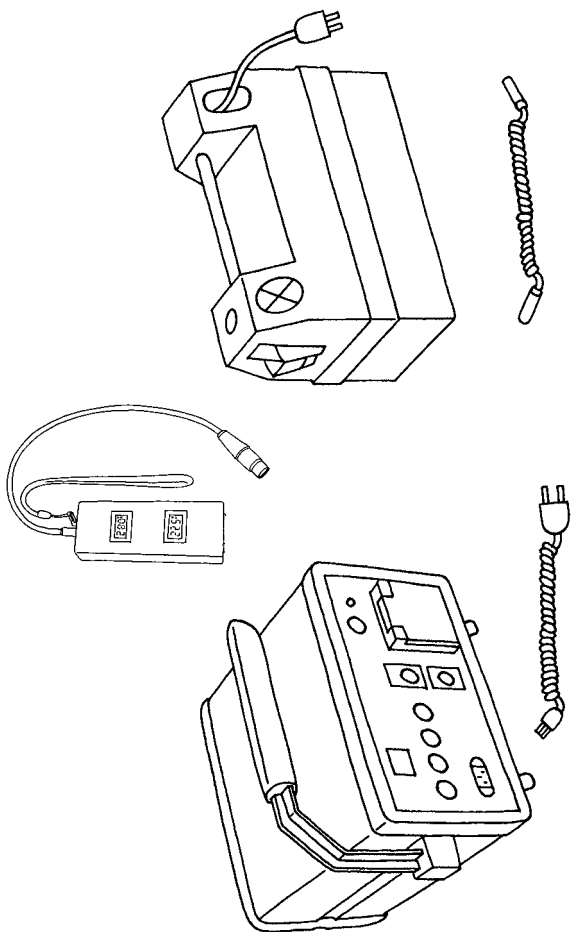

CHAPTER 8  
THE POWER SUPPLIES

# CHAPTER 8

## THE POWER SUPPLIES

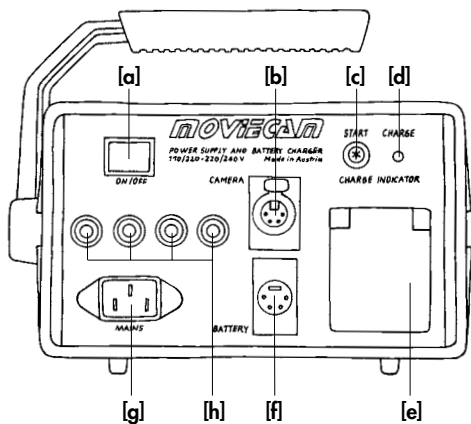

Fig. 37 – THE POWER SUPPLY

- [a] - Main switch
- [b] - Camera supply 24V / 8A stabilized
- [c] - Charge start button
- [d] - Charger control green LED
- [e] - Plug socket 110V or 220V
- [f] - Battery charger 24V / 1,3 A
- [g] - Connector 110V / 220V, 50/60 Hz
- [h] - Fuse

rear side 1 x 2 A glass fuse  
 front side 8 A automatic fuse  
               2 A automatic fuse  
               2 A automatic fuse  
               2 A automatic fuse

*The camera is powered either by the MOVIECAM POWER UNIT or a MOVIECAM BATTERY BLOCK. The MOVIECAM SL is operated with a constant voltage of 24 V. Under normal working conditions (approx. 25° C / color film in SL 400 ft - 120m MAGAZINE / 24 fps), the camera consumes 2,5A. The camera red diode lights up in case the voltage drops below 20,5 V.*



The integrated, thermostatically controlled heating elements need approx. 15 W, even when the camera is not running.

A stabilized 24 V (direct current) outlet, a 110 V / 220 V (alternating current) outlet and a lead battery charger are integrated in the POWER UNIT body.

**Caution:**

**Prior to connecting the power unit with the mains, check the given voltage and, if necessary, adjust the selector at the power unit rear accordingly!**

When the camera is connected, you can simultaneously charge a BATTERY BLOCK. You have to switch on the main button **[a]** of the POWER UNIT not only to operate the camera (switch lights red), but also when the power unit serves as battery charger.

Charging needs approx. 4-6 hours and is indicated by a green diode **[d]** lighting up. It fades out when the battery is fully charged. Start charging by pressing the small button "charge" **[c]**.

Use the plug socket **[e]**, secured by a 2 A automatic fuse, to charge a second battery block via its in-built charger or to supply e.g. an "Obie light" (max. 300 W / 220 V) or a video recorder.

At the power supply unit rear, there are the voltage selector and the glass fuse 2 A slow (5 x 20 mm).

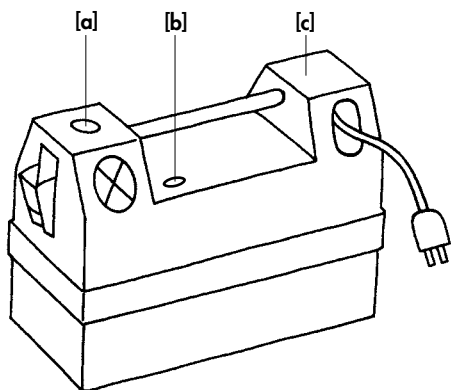

Fig. 38 – THE MOVIECAM BATTERY BLOCK

*The 7Ah 24V MOVIECAM BATTERY BLOCK is an assembly of lead cells.*

*To charge, either connect the BATTERY BLOCK to the POWER SUPPLY UNIT charger or use the built-in charger.*

*The built-in charger [c] operates with 220 V.*

**Caution: Prior to operating the built-in charger with a different voltage, contact the rental house!**

*The green LED [b] lights up during charging period. After the BATTERY BLOCK has been fully charged, in approximately 6 hours, the on-board charger switches off and the LED extinguishes.*

*To operate the MOVIECAM SL, plug the red CAMERA CABLE into the 24 V outlet [a].*



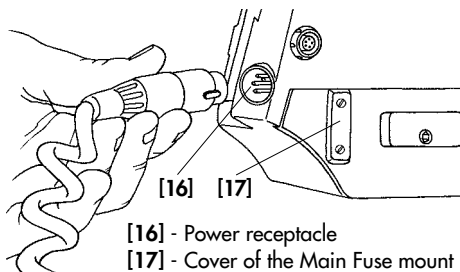

Fig. 39 – CAMERA POWER SUPPLY

MOVIECAM provides two special coiled cables. The blue cable connects the mains with the POWER SUPPLY unit. The red cable connects the POWER SUPPLY unit or a BATTERY BLOCK with the SL.

Both coiled cables may be stretched up to approx. 2,5 m. **Do not overstretch!**

As the voltage may drop up to 1 V per cable length (depending on the power consumption of the camera), **do not use a longer cable.**

The camera cable can be easily plugged into the sloped connector **[16]**.

The leverage caused by connector length and cable weight resp. strain might damage the socket attachment. Therefore it is recommended to protect it against tension, e.g. by attaching the cable at the fluid or geared head.

If the camera is properly connected to a power supply (loaded battery or main adapter), the display will light up and the camera is ready to run. In case it does not light up, you have to check with a meter if 24 V are supplied. If this is the case, remove the small cover **[17]** and exchange the glass fuse 5 x 20 mm (6,3 A / slow). If the display does not light up or the camera does not run after the exchange, the camera has to be checked at the rental house.

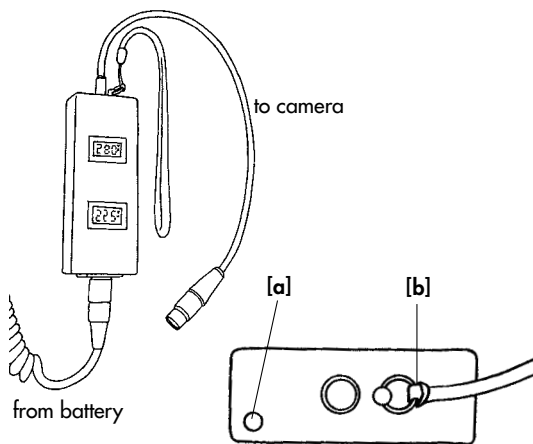

Fig. 40 – ADJUSTABLE VOLTAGE STABILIZER

*The MOVIECAM DC-DC converter stabilizes the battery voltage to the maximum performance for the SL.*

*The input range is 18 – 36 V dc*

*The output range is 24 – 28 V dc*

*The max. output power is 150 W.*

*Operation:*

- 1. plug the battery cable to the power receptacle at the base of the unit,*
- 2. adjust the desired voltage, e.g. 24 V, by means of a 2mm screw driver introduced in the little hole on the top of the unit [a],*
- 3. connect the Adjustable Voltage Stabilizer to the camera,*
- 4. A strap [b] should help you securing the Stabilizer in order to prevent any restriction of the camera's and operator's movement.*

**Notes:**

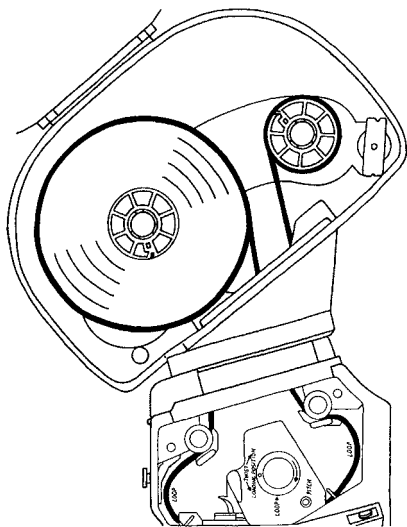
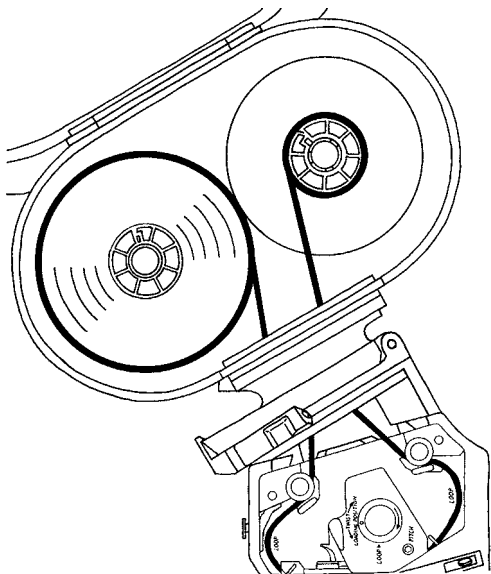

## CHAPTER 9 THREADING THE SL

# CHAPTER 9

## THREADING THE SL

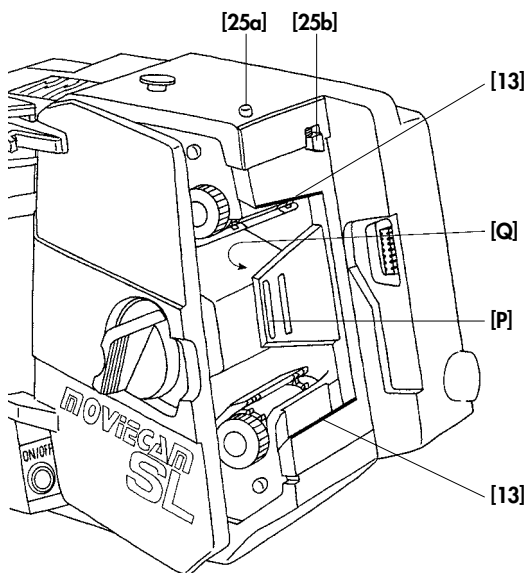

Fig. 41 – CAMERA DOOR LOCK

- [13] - Mounting rail
- [25a] - Magazine / Magazine adapter release button
- [25b] - Magazine / Magazine adapter lock
- [P] - Door lock counterpart
- [Q] - Rear buckle switch

*The door lock is designed in a way that, when turning this lock, the door is pressed onto the body which protects it against light leakage.*

*In case the door does not close properly, check whether the movement block is in its front position and the film guides are closed.*

*Only then the door can be locked properly.*

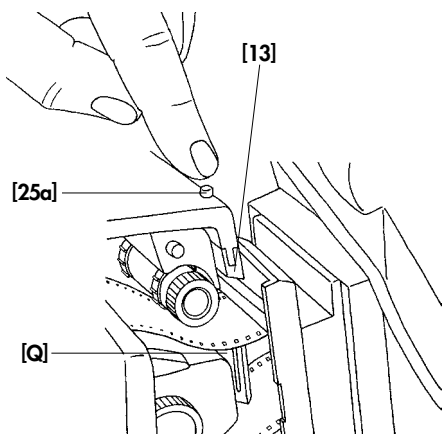

Fig. 42 – THE MAGAZINE/ADAPTER MOUNTING RAIL

Contrary to the magazine receptacle of the SUPERAMERICA and the COMPACT, where the magazines are suspended on a rail and swing towards the camera body, the magazine receptacle of the SL is designed with an upper and a lower rail **[13]** where the SL magazines are slid on.

On top of the mounting rail is a lock to secure the magazine or the adapter. By pressing the small knob **[25a]**, this lock **[25b]** (Fig. 42) is released and the magazine or magazine adapter can be removed. The rear buckle switch **[Q]** is located on a plate in the middle of the magazine receptacle. This plate serves at the same time as counterpart of the door lock.

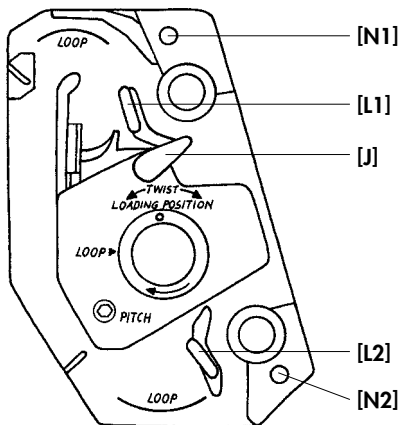

Fig. 43 – THREADING FILM IN THE SL

1. Open camera door.
2. Bring the movement to its rear position by turning the lever **[J]** clockwise.
3. Swing away the rear film guides **[L1+ L2]** by pressing the release knobs **[N1+ N2]**
4. Pull film loop (approx. 10 cm) out of magazine.





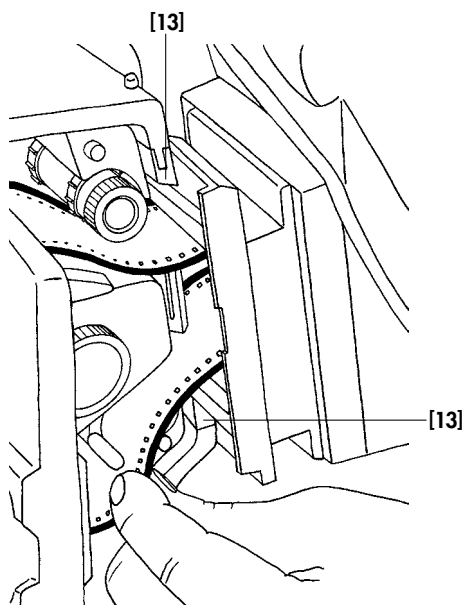

Fig. 44 – THREADING FILM IN THE SL

5a. *Threading the film in the SL using the  
SL MAGAZINES*

*Slide the magazine onto the body until you hear a  
"click".*

***Take care not to put the magazine on its edges,  
do not force!*** →

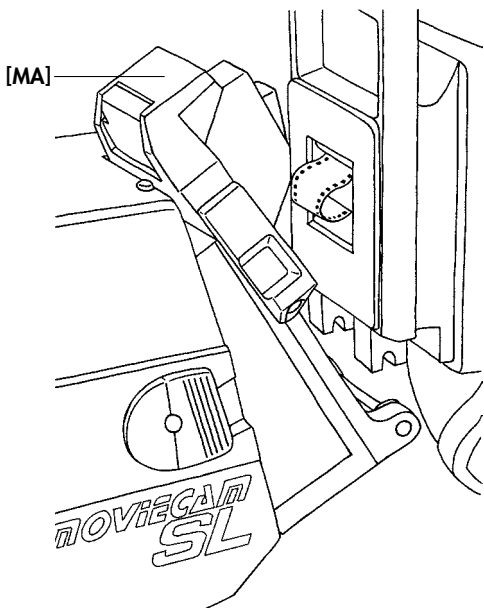

Fig. 45a – THREADING FILM IN THE SL

5b. Threading the film in the SL using the SL MAGAZINE ADAPTER **[MA]** and COMPACT MAGAZINES

Install the SL MAGAZINE ADAPTER like an SL MAGAZINE by sliding it onto the rail until you hear a "click". →

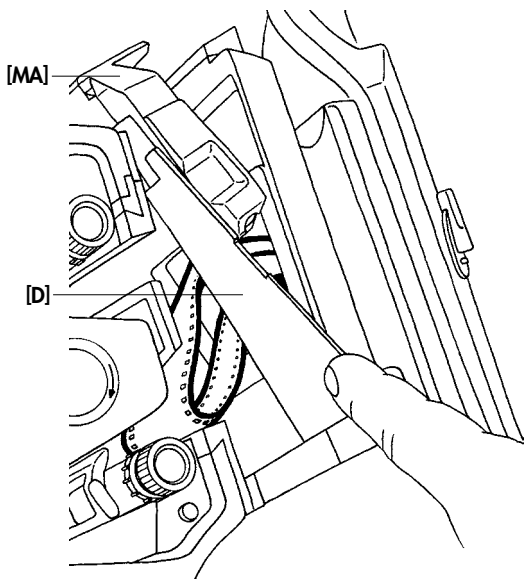

Fig. 45b – THREADING FILM IN THE SL

*Attach magazine mounting claw to the adapter mounting rail. Insert film loop through the adapter in the camera.*

*For easier threading, the adapter door **[D]** can be opened.*

*Grab the film loop and swing magazine forward toward the adapter until it engages in the latch.*



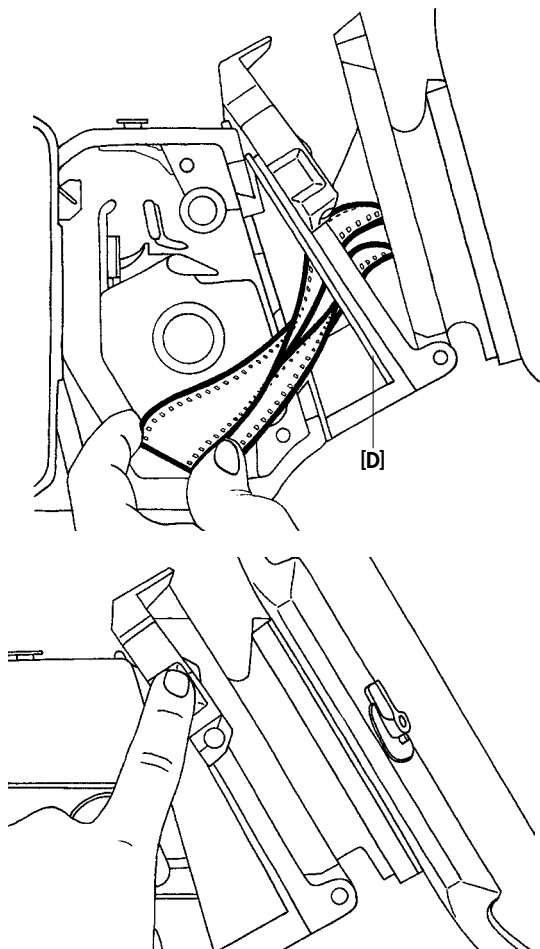

Fig. 46 – THREADING FILM IN THE SL

**Caution: The latch of the adapter must be open!**

**Do not crimp or fold the film!**

**Do not forget: Lock the magazine on the adapter by pulling the adapter locking lever forward. →**

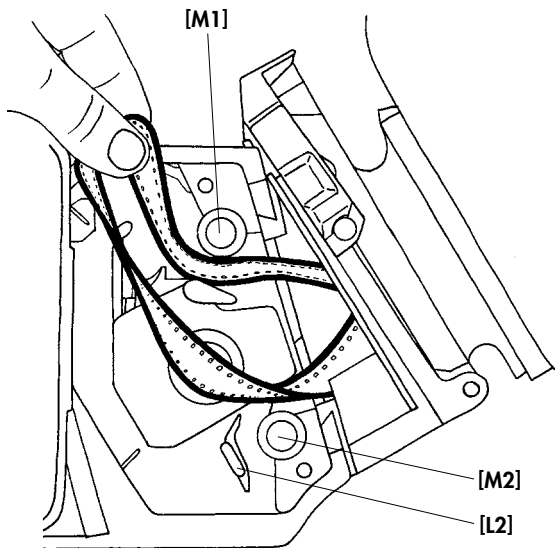

Fig. 47a – THREADING FILM IN THE SL

*From now on same handling with SL or COMPACT MAGAZINES.*

- Pull film loop toward film gate and insert between film guides [L1 + L2] and sprocket-wheels [M1 + M2].* →

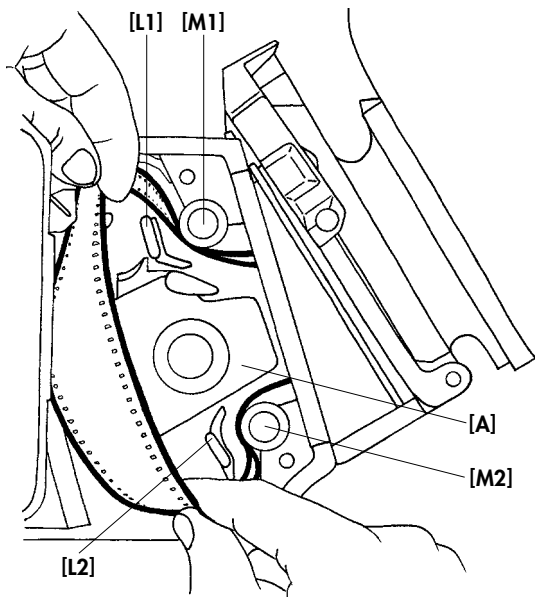

Fig. 47b - THREADING FILM IN THE SL

*Then thread film between film gate and movement block [A] in a not too narrow loop.*

**Caution: As soon as you connect the camera, the film winders are shortly activated to tighten the film. Turning the inching button also activates these winders. To avoid this when loading film, just disconnect the camera from power. →**

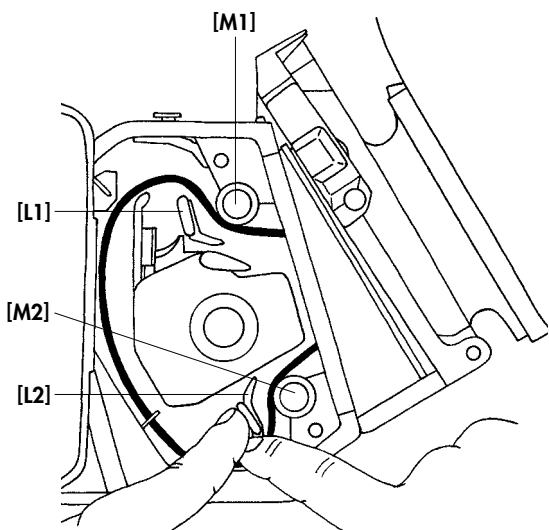

Fig. 48 – THREADING FILM IN THE SL

7. Swing guide rails toward the sprocket-wheels **[M1 + M2]** by moving the latches **[L1 + L2]**. →

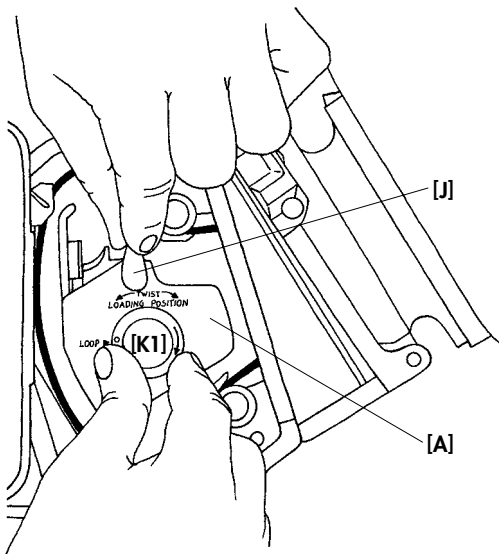

Fig. 49 – THREADING FILM IN THE SL

8. Turn the lever **[J]** with one hand gently counter-clockwise to move the movement block **[A]** into its front position. Simultaneously, turn inching knob **[K]** with the other hand to the left and right within the range of the "TWIST" mark to engage the pulldown claws gently and properly in the film perforations. Only then lock the movement block by further turning the lever **[J]** counter-clockwise until it engages in its front position.

**Caution:**

**Sprocket must engage properly in perforation!**





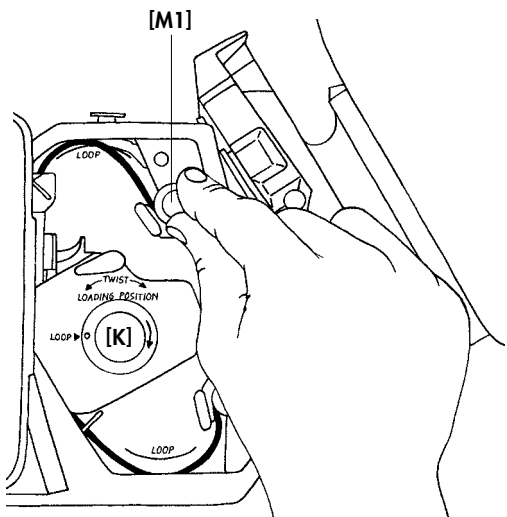

Fig. 50 – THREADING FILM IN THE SL

9. To adjust loop length, turn inching knob **[K]** to the position (dot) marked "LOOP".
10. Form upper film loop to the "LOOP" mark engraved on the rear side of the camera interior by depressing and turning the sprocket button **[M1]**.  
→

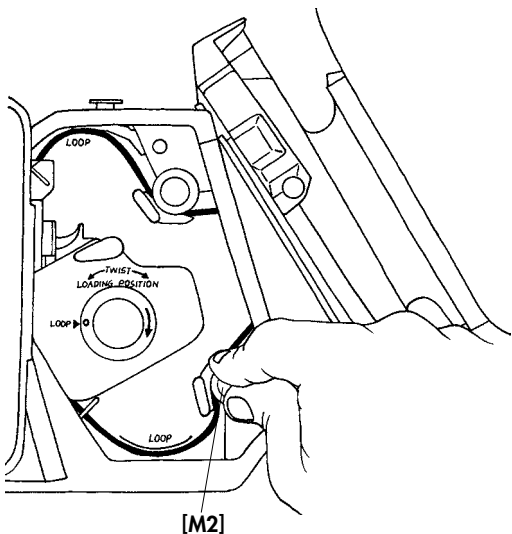

Fig. 51 – THREADING FILM IN THE SL

11. Repeat this procedure with the lower film loop.
12. Film should always be tightened now by the winders. If not, check that the locking levers are in shooting position. The film is tightened by **shortly** pressing the multi-functional knob **[9]** (see Fig. 52).
13. To conduct a test run, run camera shortly at its regular frame speed.
14. When closing the camera door, care should be taken that the camera interior is clean and the door lock is flush with the door.

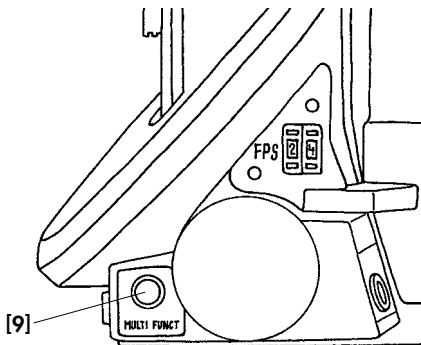
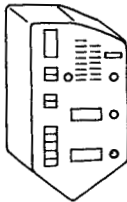
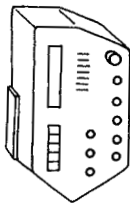
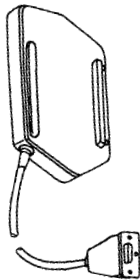
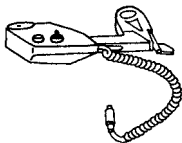
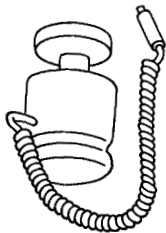
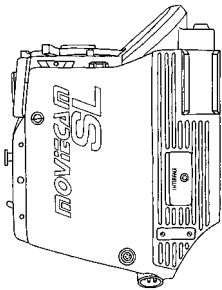
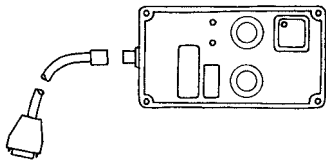
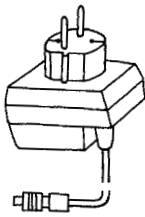

Fig. 52 – DUST CHECK

When manually switching off the camera, the electronic system of the MOVIECAM SL automatically sets the mirror shutter to "viewing position". To inspect the gate without opening the camera, set the mirror shutter to shooting position by pressing the multi-functional button [9] for **2 seconds**. Inspect the gate by either shining a flashlight through the lens or removing the lens. By pressing the multi-functional button, the letters "dc" are displayed on the control board. The camera can then be switched on only after pressing the multi-functional button once again, which sets the mirror shutter to "viewing position".

**Caution:**

**Before cleaning the film gate (with great care!), disconnect the camera to prevent possible accidents or damage. When the camera is connected again, the electronic system is automatically reset ("stand by" mode); the mirror shutter, however, remains in the shooting position and can be moved by pressing the multi-functional button.**



## CHAPTER 10 THE ACCESSORY BOXES

# CHAPTER 10

## THE ACCESSORY BOXES

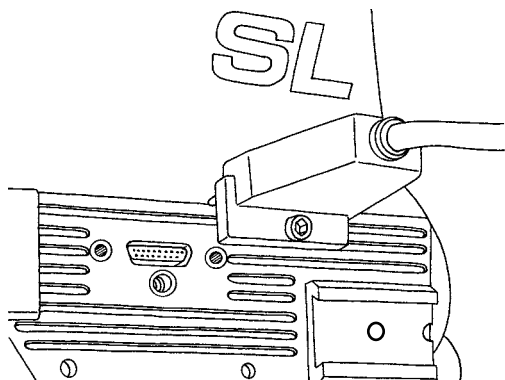

Fig. 53 – THE ACCESSORY CONNECTOR

From the MOVIECAM family, three ACCESSORY BOXES can be used with the SL:  
the SUPER SPEED CONTROL BOX, the SYNCO BOX and the REMOTE CONTROL BOX.

**Those ACCESSORY BOXES must be new types which have digital displays.**

The AATON CODE BOX cannot be used because the SL is not equipped with an LED to record the code.

In order to use the SUPER SPEED CONTROL BOX and the SYNCO BOX, MOVIECAM supplies an interface cable.

The REMOTE CONTROL BOX is provided either with a plug for attachment on the COMPACT VIEWFINDERS or with an SL connector.

After removing the small cover **[18]** (see Fig. 5/page 23) at the camera right side, you may plug the INTERFACE CABLE or the REMOTE CONTROL CABLE into the accessory connector and secure it with an M5 Allen screw.

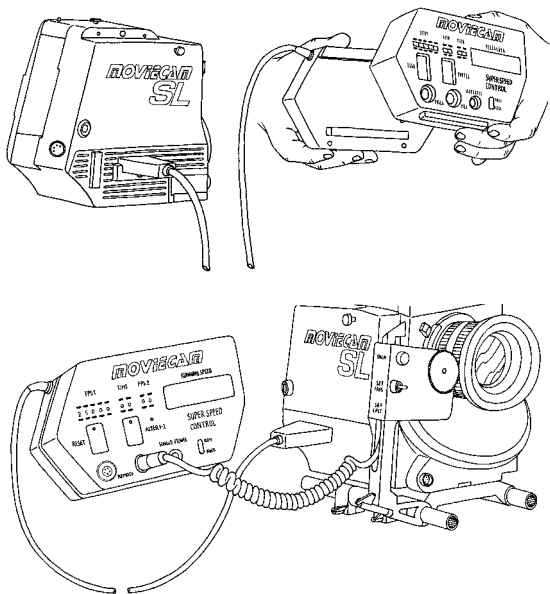

Fig. 54 – THE ACCESSORY BOX INTERFACE

*At the other end of the interface cable, there is an attachment plate to mount the boxes.*

*Features and handling of the boxes, including the IRIS CONTROL device, the SPEEDBOX REMOTE CONTROL WHEEL and the MAIN SYNC ADAPTER, are described in the COMPACT USERS GUIDE.*

**Please do not forget:**

*Using the SPEEDBOX, you may shoot forward from 2 to 40 fps (not 50 fps, as with the COMPACT). If you want to shoot reverse (12 to 32 fps), you have to use a COMPACT MAGAZINE.*

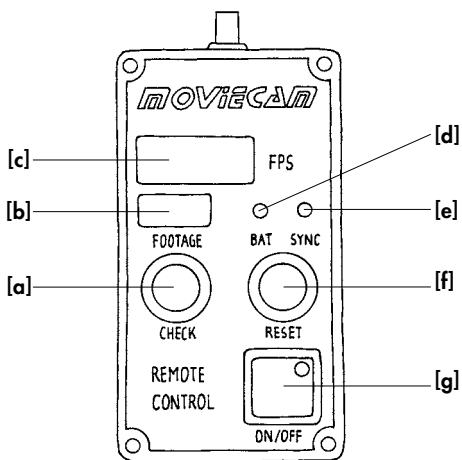

Fig. 55 – REMOTE CONTROL

To connect the SL REMOTE CONTROL CABLE with the MOVIECAM SL camera, remove first the interface plug cover (Fig. 5 [18]) on the right side of the camera; then plug in the connector.

When using viewfinders from the COMPACT system, you may also use the COMPACT REMOTE CONTROL CABLE.

The REMOTE CONTROL BOX works as both on/off switch [g] and "remote" READOUT. You can read exposed footage [b], frame speed [c], battery condition [d], sync speed [e] and warning signs up to a distance of 10 m. As long as the REMOTE CONTROL BOX is connected to the ready-to-shoot camera, the display [c] is on. By pressing the check - button [a], the preset frame speed or a warning sign appears on the "FPS"-display. It can be reset to "0" by pushing the reset button [f]. The "FPS" will be shown when you switch on the camera.



**Notes:**

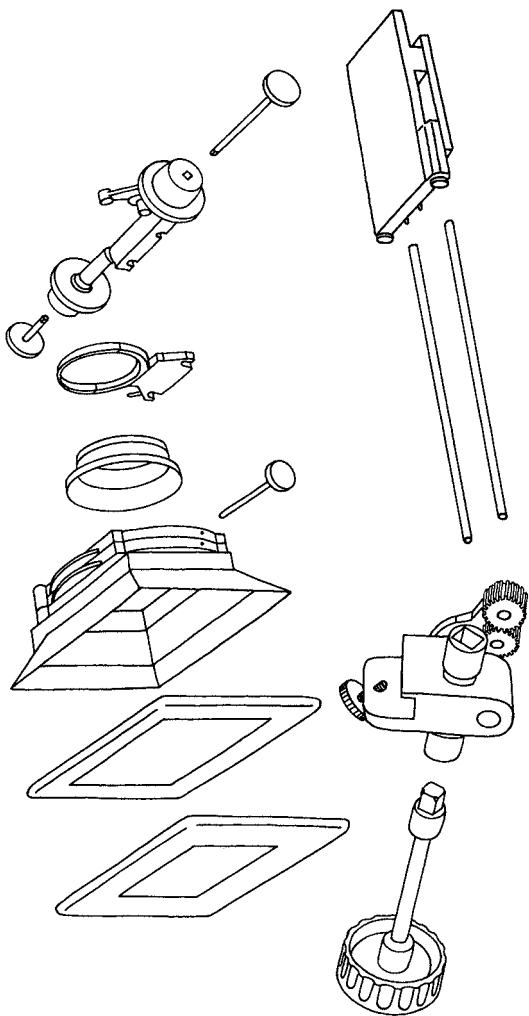

CHAPTER 11  
SUPPORT, FOLLOW FOCUS AND MATTE BOX

# CHAPTER 11

SUPPORT, FOLLOW FOCUS  
AND MATTE BOX

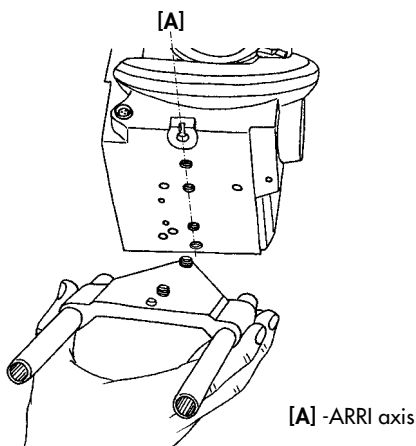

Fig. 56 – CAMERA BASE PLATE

**Remarks:**

*Apart from the SL LIGHTWEIGHT BASE PLATE, further support systems of the MOVIECAM COMPACT can be used together with the SL.*

*There is one important difference, however, between COMPACT and SL: the camera base of the SL is provided with bore holes in ARRI axis standard only. SUPPORT RODS and, subsequently, LENS SUPPORT, MATTEBOX, STUDIO FOLLOW FOCUS etc. are attached to the base plate. You will not need the plate when using prime lenses, flanged FILTER HOLDERS, SUNSHADES and LIGHTWEIGHT FOLLOW FOCUS.*

**Caution:**

***In case no original MOVIECAM base plate is used, do not screw the attaching screws further than 7 mm into the threaded sockets of the camera base. Longer screws may damage the camera. When attaching the base plate, care should be taken that it sits flat on the camera base.***

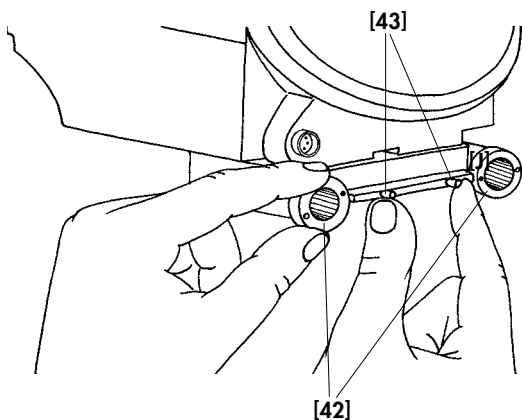

Fig. 57 – BASE PLATE (35/S 35)

[42] - Adjusting rings

[43] - Locking lever

*The support rod brackets on the MOVIECAM BASE PLATE are mobile. This is of advantage when shifting the optical axes for shooting in either STANDARD 35 or SUPER 35 format.*

*The rod brackets can be adjusted to either format by turning the asymmetrical rings [42]. Just press both sliders [43] toward the center and turn the rings so that each one of the two dots of the same color face the center and the locating pins engage in the holes.*

*White = STANDARD 35 format*

*Red = SUPER 35 format*

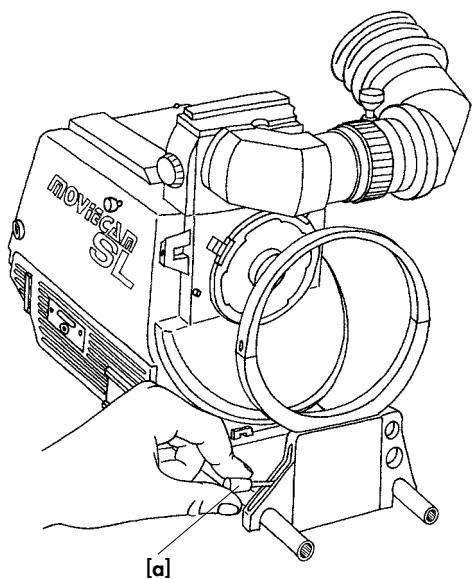

Fig. 58a – LENS SUPPORT

*Mount the LENS SUPPORT to both SUPPORT RODS and tighten the lever [a].*

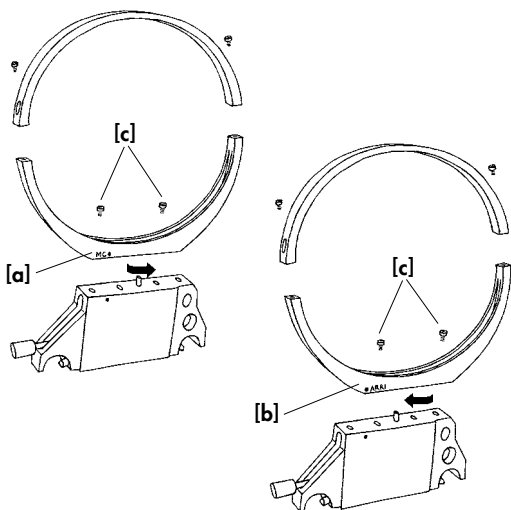

Fig. 58b – LENS SUPPORT

The MOVIECAM LENS SUPPORT can be adjusted to either MOVIECAM (MC) **[a]** or ARRIFLEX (ARRI) **[b]** standard.

The lower part of the support ring is attached asymmetrically and may thus be turned 180° after loosening the two M4 Allen fixing screws **[c]**. This shifts the ring's central axis to the center of the standard selected.

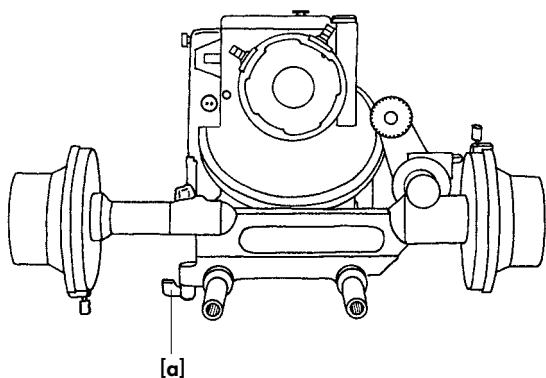

Fig. 59 – STUDIO FOLLOW FOCUS

*Slide the MOVIECAM FOLLOW FOCUS onto the SUPPORT RODS and tighten it with the lock lever **[a]**.*



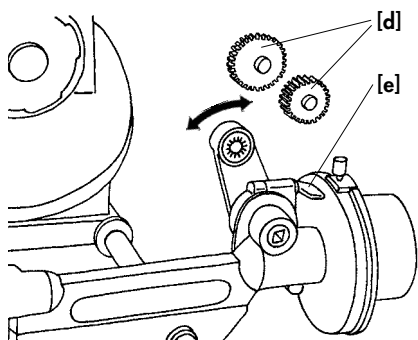
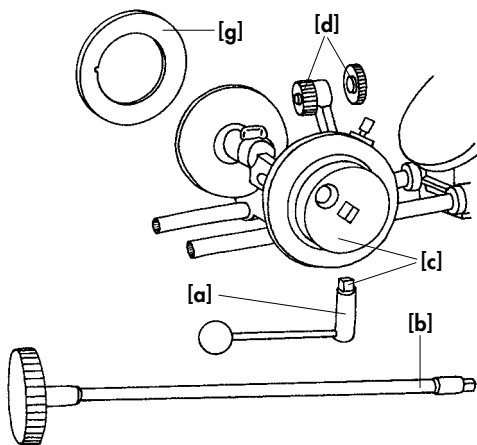

Fig. 60/61 – STUDIO FOLLOW FOCUS

MOVIECAM provides several accessories for the STUDIO FOLLOW FOCUS, e.g. focus extension levers **[a]** and flexible shafts **[b]** (easy to mount with a squared stick-in system **[c]**), as well as various gears **[d]** for the different lenses, e.g. COOKE, ZEISS, CANON, ANGENIEUX and MOVIELENS. Loosen the locking lever **[e]** and swing the small driver arm **[f]** toward the lens gear. →

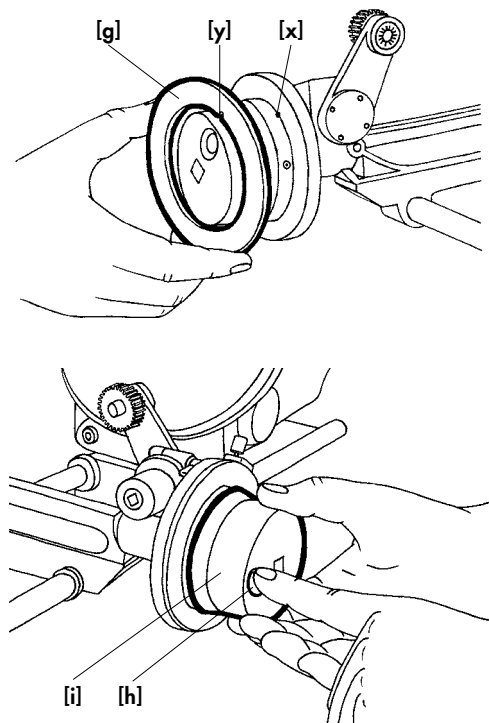

Fig. 62/63 – STUDIO FOLLOW FOCUS

For each lens, two magnetic discs **[g]** for individual marks should be available – one for each side of the FOLLOW FOCUS.

**Caution:** When attaching these discs, the locating pins **[x]** have to engage in the holes **[y]**.

The STUDIO FOLLOW FOCUS has a two gear drive. To change gear, press the small button **[h]** and simultaneously move the wheel **[i]** forward or backward.

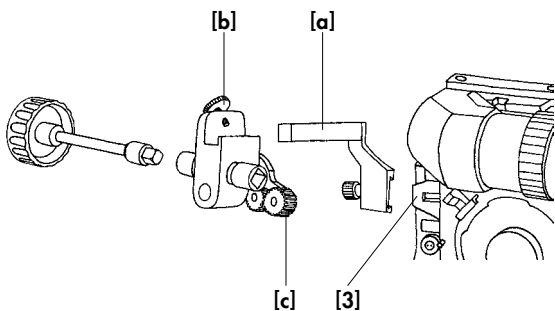
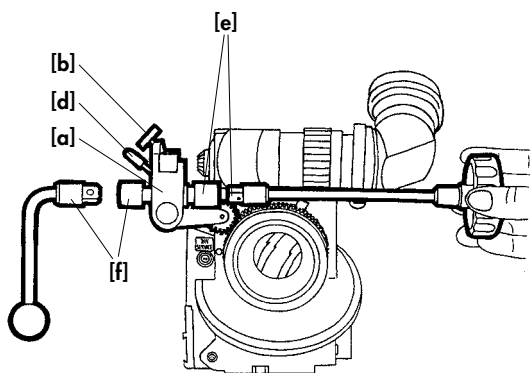
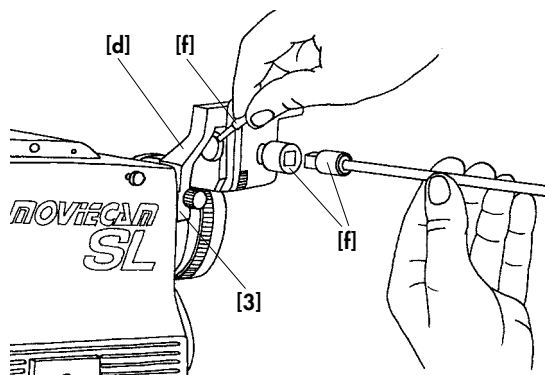

Fig. 64 – LIGHTWEIGHT FOLLOW FOCUS

The MOVIECAM LIGHTWEIGHT FOLLOW FOCUS is used mainly for handheld operation. It has no scales; the distance has to be read directly off the lens barrel. After the squared support rod **[a]** is attached with a screw to the dove tail bracket **[3]** on the camera front, mount the LIGHTWEIGHT FOLLOW FOCUS to this rod. Fix it with the screw **[b]** until the gear **[c]** attached to the driver arm engages in the lens gear. →



— Fig. 65/66 – LIGHTWEIGHT FOLLOW FOCUS —

The lever **[d]** at the rear of the *LIGHTWEIGHT FOLLOW FOCUS* is used to swing and adjust the small driver arm. A small gear, used for prime lenses (e.g. ZEISS), is attached to the end of this arm.

The operating wheels are attached to either left **[e]** or right **[f]** side of the follow focus.

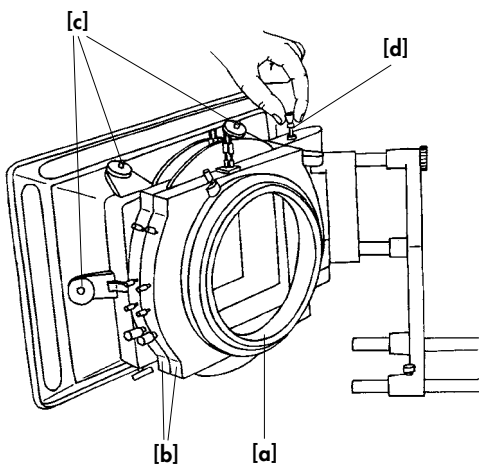

Fig. 67 – MATTE BOX

This MATTE BOX is equipped with two filter stages **[b]** for altogether four 6.6" x 6.6" filters, two each rotatable and sliding through, as well as two toothed filter frames, operable with a rotary knob or flexible shaft. The 4x filter stage has a receptacle **[a]** on the rear for 6", 138mm or 4 1/2" filter rings, as well as for reflex prevention rings **[e]** and an additional 4" x 4" filter stage. The 4x filter stage can be interchanged against other filter stages. The MATTE BOX can be swung open to the front for easy lens cleaning.

By lifting the lever **[d]** on the top right side, unlock the MATTE BOX and swing it open to the front. After swinging it back, care should be taken that the lever locks into place again. Additional holders **[c]** on the MATTE BOX serve for fastening French flags. →

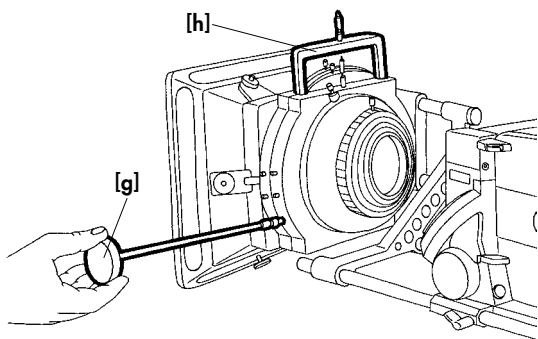
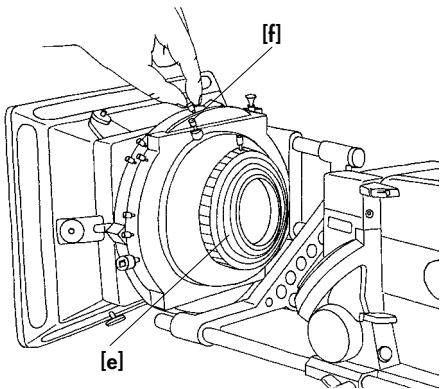

Fig. 68/69 – MATTE BOX

The MATTE BOX holds two filter stages for altogether four 6,6" x 6,6" filters, two each rotatable (knob **[f]**) and sliding. Each filter stage has an attachment at the rear for 6" , 138 mm or 4 1/2" filter rings, rubber donuts (reflex prevention rings) **[e]** and an additional 4" x 4" filter holder.

Some filter stages have a gear drive that may be operated with the hand wheel **[g]** via a flexible shaft to move a toothed filter frame **[h]**.

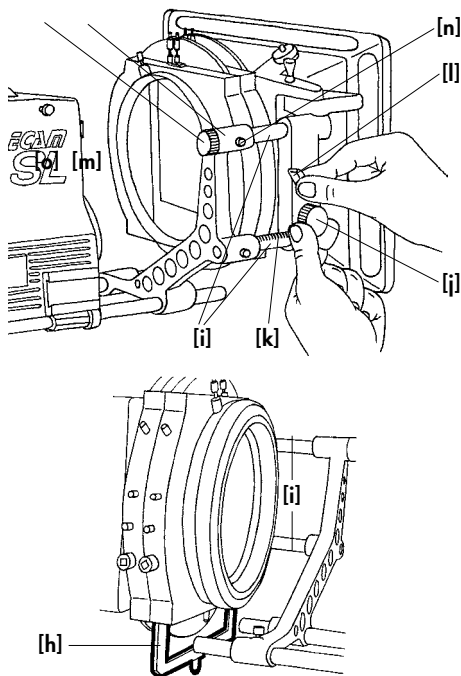
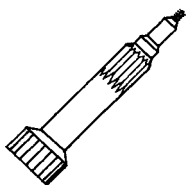
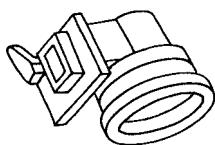
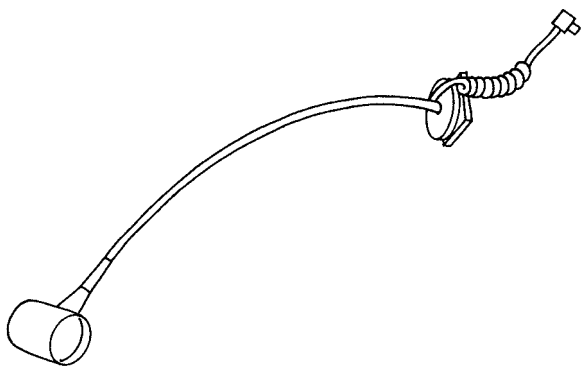

Fig. 70/71 – MATTE BOX

The MATTE BOX with its filter stages is attached mobile to two short rods [i]. The gear [j] engages in the toothed lower rod [k]. To move the MATTE BOX forward or backward without having to move the whole bracket, loosen the locking lever [l] and turn the gear [j]. The asymmetrical upper bracket [m] allows to adjust the MATTE BOX to the lens more precisely. Loosen the adjusting screw [n] and turn the knob [o] at the rear end of the upper rod.

**Caution: When using graduate filters, care should be taken that the filter, when in its lower position, does not touch the rods.**





# CHAPTER 12

## MISCELLANEOUS

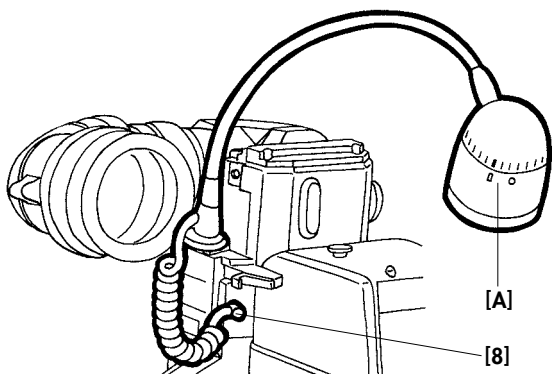

Fig. 72 – ASSISTANT WORK LIGHT

- [8] - Connectors
- [A] - On/off switch

The ASSISTANT WORK LIGHT is mounted either on top of the SL body, on top of a READOUT or on top of a MOVIELITE like a flash to a still camera.

After loosening the fixing screw, slide the light shoe into one of the several brackets and tighten the screw.

Disconnect the camera, then connect the short coiled cable (similar to that of the eyecup heater) to the connector [8]. The light is switched on by turning its cap [A].

Always carry a spare bulb (24 V/4 W) with you.

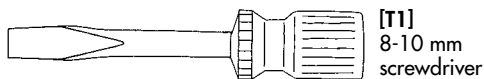

**[T1]**  
8-10 mm  
screwdriver

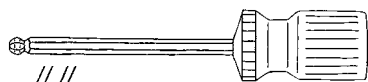

**[T2]**  
5 mm ballpoint  
hex socket  
screwdriver  
(M5 Allen  
screwdriver)

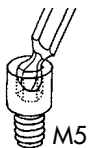

**[T3]**  
2 mm screwdriver

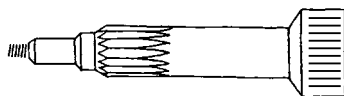

**[T4]**  
MOVIECAM  
COMBITOOL

Fig. 73 – TOOLS

*In addition to the various cleaning tools, the camera assistant needs only four other tools to work with the MOVIECAM SL:*

*With [T1], you attach the BASE PLATE to the camera.  
With [T2], you can mount and remove e.g. VIEW-FINDER, HANDGRIPS etc.*

*[T3] is used for different tasks which should, however, best be left to the experts of the rental house.*

*With [T4], you exchange the GROUND GLASS and set the mirror shutter angle.*

***Caution: Compressed air should only be used for blowing the magazines! Apart from this, high pressure does more harm than good, especially to glass surfaces.***

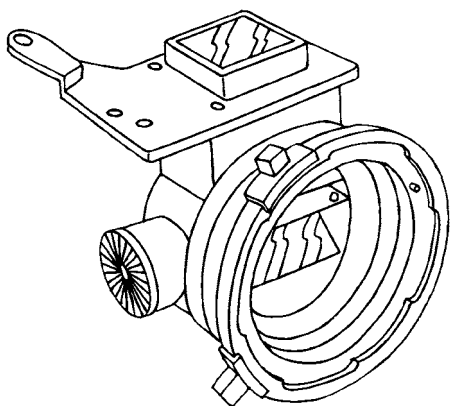

Fig. 74 – DIRECTORS FINDER

*The DIRECTORS FINDER allows to look for set-ups by using the lenses of the MOVIECAM SL. GROUND GLASSES, COMPACT VIEWFINDER systems and RIGHT HANDGRIP may be attached to the directors finder in the same way as to the camera.*

*VIEWFINDER - even VIDEO CAMERAS, prime lenses, an own GROUND GLASS (same format as in the MOVIECAM SL) and RIGHT HANDGRIP are usually mounted to the DIRECTORS VIEWFINDER. The threaded socket (M5) at the rear of the finder and the pin hole can be used as finder attachment.*

*Now that you have read the whole manual, you already know the SL by heart.*

*Just attach the tape measure to the hook and start shooting.*

*Good luck!*

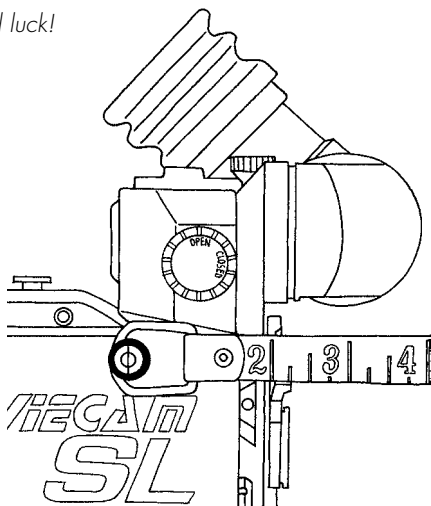

**Notes:**

# APPENDIX

## CONNECTORS AND CABLES

## CONNECTORS AND CABLES

**Warning! Diagrams show factory standard. Socket and/or pinning might have been changed by some rental houses.**

### SYNCO BOX

**SYNC IN** (female)

Top View

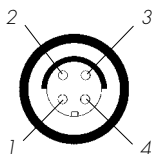

- 1 SYNC IN
- 2 MAINS IN 5V AC MAX
- 3 MAINS IN 5V AC MAX
- 4 GND (Ground, Return for Pilot)

Socket type: FISCHER D 103 A 053

### VIDEO CAMERAS

**VIDEO ASSIST OUT** (female)

Top View

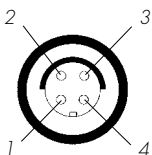

- 1 GND (ground)
- 2 +12V DC
- 3 N.C.
- 4 VIDEO SIG. OUT

Socket type: FISCHER D 102 A 053

### MOVIECAM PILOT CABLE

FOR NAGRA IV PLUG (Bottom view)

MOVIECAM

**SYNC OUT**

NAGRA

**SYNC INPUT**

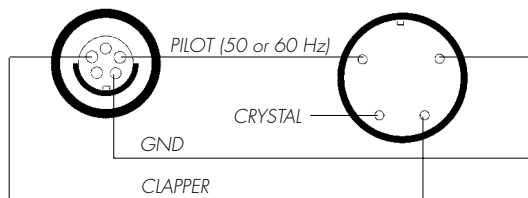

Plug type: FISCHER S 103 A 054

male

BINDER 680-1-9-0309-00-04

male



## CONNECTORS AND CABLES

### CAMERA FRONT

24 V SUPPLY OUTLET

 (female)

Top View

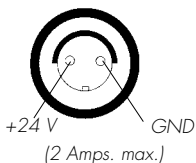

Socket type: FISCHER D 103 A 051

### CAMERA RIGHT SIDE

SYNC OUT

 (female)

Top View

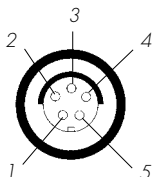

- 1 SELECT PILOT  
NC-50 Hz  
GND-60Hz
- 2 CLAPPER for NAGRA
- 3 TRP/ 1,7 m SEC
- 4 PILOT (5V AC, PEAK-PEAK)  
selectable  
50Hz at 25 FPS, 24 FPS  
60 Hz at 24 FPS
- 5 GND (Ground, Return for Pilot)

Socket type: FISCHER D 103 A 054

### MOVIECAM DC SUPPLY CABLE

BATTERY

CAMERA

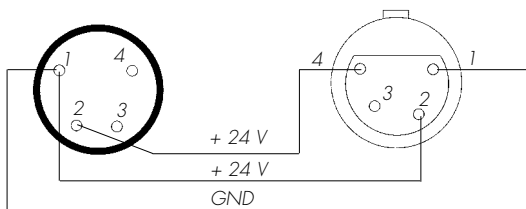

4 PINS XLR (male)

4 PINS XLR (female)